

MICHAEL HAROLD

Art and Technology

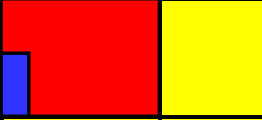

A Visual Sound and Movement Company

Art and Technology

Michael Harold

Cover illustration by Michael Harold

Copyright 2004 by Michael Harold. All rights reserved.

To my Mother, Edith Louise Dial and my Father, Raymond Rico Aro

I

Art for Art's Sake

Is there a plot?
There's a plot.
No there isn't.
Yes, there is.
No, there isn't.

Possessing rationalization and denial in equal measure, confident in the undertaking, I thought, on the occasion of writing this, that Laurence Sterne's *Tristram Shandy* and James Joyce's *Finnegan's Wake* are two books that the brightest, most talented, inspired and ambitious students of literature, with few exceptions, eventually regret having read or tried to read, not because they are too long or incomprehensible (which *Finnegan's Wake* most certainly is), but because they insist in the name of progress and with all the authority of their authors' genius on the possibility of seeing the world and everything in it as a collection of universal product codes. I could be wrong. And then I thought, This book is no different. The history of anything is an inventory of memories and desires. And no matter how you do it (with or without a computer) you almost always end up with words in a row, that is to say, narrative. This happened. And then that happened. First there was nothing. Then time and space happened. Then cause and effect happened. Then language, the names of things. And finally, stories. Every tree has a root and every tree is a tree, no matter how few or many branches it may hold. Even if it has been grafted, a seed had to come from somewhere. There is no way around it, this comic *Source Wall*. If there were another path I would take it, if only to see where it leads.

It
's m
uch ea
sier if so
mewhat boring t
o prefer combinations of
known things to the making up of new thing
s.ings.
where art is concerned.

A novel?

1. A box, purchased at a yard sale containing a number of items previously owned by Elihu Tellus, an itinerant theologian influenced by the work of A. N. Whitehead and Aldous Huxley, husband to the poet and writer Joyan Bliss.

2. In the box, an unpublished work titled *St. John's Monkey Hour* by Tellius, several technical papers, an interview with the artist Miguel Aro, an annotated chess game between Mikhail Tal and Bobby Fischer, a novelty post card, several collections of short pieces, poetry, a travel chess set.

. . . From January to May, Joyan disappeared from public view. She had married one Harry Frederick Cowper who left for no apparent reason. She later found out he had previously married her cousin who was serving time in prison for polygamy. In June she resurfaced, and soon after published her first book of poetry, *Va te faire foutre!* (i.e., *Go Fuck Yourself!*), originally in French, and only much later in English. In 1956 she published her landmark work, *Woman In A Box*. She later claimed to have been Joseph Cornell's lover at the time and the inspiration for his work, *Apollinaris*. In 1981 she married Elihu Tellius, thirty years her junior, and retired to the country where she continued to write in privacy and relative poverty. Between 1985 and 1991 she wrote *Easel* and *Dead Ballerinas*. Her last book, *Auygana*, was published posthumously in 1998. Her view of herself as a writer is probably best summed up in the opening paragraphs of *Auygana*:

Outsiders sometimes make the best artists and dissidents, not only because they begin their efforts estranged from the centers of power in any given group and as a result have an outsider's objectivity with regard to prevailing habits and assumptions, strengths and weaknesses, but also because their brain is wired differently as a result of their earlier experiences. If they are a mathematician become poet, they tend to write mathematical poetry (Queneau). If they are a musician become painter, they tend to compose paintings (Klee). Although art often evolves mimetically (Mondrian) a lot of it is also the result of conceptual cross-pollination (Cage). This has been the case for centuries if not thousands of years. It has certainly been the case with me. I have come to believe, however, that in the coming century, significance as an artist or intellectual will be more the result of having the right agent, a brand vision, and a global media presence than any other factors.

And now, on with the story.

aAbBcCdDEeFfGgHhIiJjKkLlMmNnOoPpQqRrSsTtUuVvWwXxYyZz . . .

On a parallel note: It is not that the author feels particularly cynical or dispossessed. A little loose in the joints maybe. It is understandable, given the millennium's shaky start. Nor does the author imagine any responsibility for or any possibility of changing society through his art. He has carefully followed the trail

of cultural mergers and acquisitions occurring throughout the middle and end of the last century and has come to the conclusion that Art is now, for all practical purposes, a wholly owned subsidiary, not of Politics or Economics as in earlier times, but of Entertainment. And although art remains his vocation, making a living as a technologist has become his full time avocation, an avocation in which he has experienced some success. Compared to most other people in the world, he is fortunate and knows it. He lives in a country that generates over 21% of the world's wealth and contains 4.6% of its population. He lives at a time (11/08/2003 12:28 GMT) in which 20% of the people in his country believe they are part of his country's richest 1% and another 19% believe that they soon will be. He lives at a time in which suicide accounts for roughly 50% of all violent deaths worldwide and in which war accounts for approximately 300,000 deaths annually or 3/64,000th of the world's population, a time in which a retrovirus with an adaptability and survivability superior to anything you can imagine (including Hollywood's "Aliens") accounts for over 3,000,000 deaths annually, the majority of the world's "non-violent" deaths, over 90% of them in underdeveloped countries (to the perpetual shame of the civilized world, a shame that no amount of years will ever erase). He lives at a time in which international military conflicts revolve around ethnicity, religion and control of the world's resources, especially oil, water, credit and debt. He lives at a time in which climatologists disagree on the ecological effects of industrial pollution, but are in almost complete agreement on the fact that the earth is getting warmer and that, if the warming continues, it may lead in fewer than twenty years to the devastation of nations and the deaths of millions. He lives at a time in which a multinational corporatism is the dominant global politic, far surpassing monarchy, theocracy, democracy, socialism and communism in its effects, and technology is the primary means by which the nation in which he lives maintains its temporary global economic, political and military superiority. He lives at a time in which the most radical stance possible is one of individual objectivity. As a result, his world, though surreal by any measure, is filled with opportunity, each day a new day, full of surprises. He knows that this is how we live now, and that things will probably get to be even more like this as time goes on, a pastiche of countless meaningful and not so meaningful statistics in various stages of production and consumption: a global society of logos, catch phrases and lists. He desires to confine the majority of his own meaningful acts to the production of art, specifically, three of its subgenres, visual art, literature and technology. He speculates that in the early years of the twenty-first century, the majority of art consumers will turn out to be slightly schizophrenic and if not schizophrenic at least suffering from one or another mild form of attention deficit disorder. Given this information, it makes the most sense from a marketing standpoint to paint and to write in ways that appeal to their sense of self(s) and/or their attention span.

Even though he cannot find Edward Craven Walker listed in any contemporary art history, he believes the lava lamp to be the apex of late modernism, a worthy successor to Duchamp's *Etant Donnes*. Sometimes, standing in front of the bathroom mirror, he might even exclaim to himself that he knows all of these things as well as he knows his own penis. As a result, he vacillates from day to day in his belief that the world is in general going uphill or downhill.

He is writing a book. His book has a protagonist but he's not sure who it is. His protagonist may be a woman. But if it turns out that his protagonist is a man, then his protagonist loves a woman. On a good day, sitting at the toilet soon after he wakes up, he will say something to himself along the lines of:

She is beautiful when she sleeps. Everything about her is beautiful. Even when she drools a little on the pillow, it never smells bad.

Why is that?

On a bad day, sitting in the same spot, he will say something along the lines of:

She sometimes looks at me as if to say, "Why won't you help me? Can't you see that I am nearly blind, that the only thing I can see anymore is the dim outline of people, two-dimensional, dark, jerking and jumping around in their shadow play? Where once I could see faces, now there are only the silhouettes of hats, hairdos, noses, lips and chins. Where once I could see the slightest motions of fingers, toes, mouths and eyes, now there are only wrists, knees and elbows." I love her. What am I to do?

And then he recites to himself:

"She entered into the center of the prison of my body and spoke: 'Rise from your deep sleep.' I wept bitter tears. Afterwards, I asked: 'Who calls my name, and where is this hope from, lying as I am in the chains of my prison?' She answered: 'I am the Pronoia of the pure light. Rise, remember, and seek your source, which I am.'"

He has picked up the habit, during business meetings, of rewriting the text on his credit card receipts as Japanese Tanka:

Alamo Circle
Hotel, Restaurant and Bar
Rest, Relax, Enjoy!

\$120

Thank you, and come again soon

Time: 2:32

Elysian Fields Full Service . . .

Customer's Copy

\$12.19

I agree to pay above . . .

Holly's Arts & Crafts

1 Sennelier Water

color Travel Set

5 Arches 90 lb. Cold

Press Watercolor Paper

The first thing you notice in the box is the postcard. It is the type of postcard you find in almost any postcard rack in certain southern states, especially Texas. It is a picture of a cowboy riding a giant jack rabbit next to a trail of cattle. Normally, at the top of the card written across the blue southern sky in cursive you would find the words, *Cattle Punching on a Jack Rabbit*. That is not the case with this card. Instead of a sky filled with carefully calligraphed letters, there is a jumble of symbols of various sorts, cut out and glued firmly to the once blue sky. Some of the symbols look familiar. Some do not. It is the kind of thing capable of capturing the mind in a trap from which the only escape is an understanding, not only of the symbols, but of their relationship to the giant jack rabbit, the cowboy, the cows, the surrounding mountains and whatever happens to be written on the other side of the card. Flipping the card over, one finds an address, and surrounding the address, in a spiral of small, hand printed letters the text:

Show me anything in this universe that isn't built with language and I'll show you the unspeakable likeness of god. That is not to say that the unspeakable is better named Unspeakable the Greater or Unspeakable the Lesser in its relationship to language (or anything else, for that matter), only that it is unspeakable. Language has been called by some the copestone of reality. It is much more than that. It is the permeable membrane of the anagogic. You can draw a line of meaning, not false meaning, but true meaning, purposeful meaning, from any point in space and time to any other. You can do this through the use of physics, mathematics and natural language. You can do this with human emotion, thought, fate, destiny and free will. You can do it with a pencil or a pen and a plane piece of paper, although in some cases, in the interest of time, a computer (such as the physical universe) may be required . . .

Language is the hallucination from which we construct reality . . .

1. Nf3

Therapy Session

Citing arguments for or against the existence of god is like picking dinner from a Chinese menu, don't you think? Despite all the seeming choices, at some point you have to decide in what combination you want your meat, fish, poultry and vegetables and whether you want them spicy or mild. In other words, you eventually come to a place where you must decide whether or not you are willing to make your own little leap of animal faith. You must decide to what degree your identity is comprised of your genetic predispositions and life's experiences. You must decide whether or not you even have an identity. Where the question of god is concerned, science is no different from any other religion. Perhaps, when it is all said and done, I am only one of an infinity of possible combinations of observable events. Each possible combination has its own belief system, prophets, priests and heretics. Perhaps my identity has no name. Perhaps my true identity is one and the same with god's. Even if this is true, even if I contain within myself everything that I think god is, I remain an infinitesimal by comparison, a point infinitely small and infinitely dense, a singularity. In a world where both absolutism and relativism have failed, god remains a necessity, not as an end state, but as a process. That is the real heresy. That god is in us and changes even as we do.

That is what he thinks to himself as he sits in a spare, tastefully decorated room, facing a woman whose head and shoulders are bathed in a golden yellow light that spills like a waterfall through a south facing, beveled glass window near the ceiling.

How are you feeling, she asks.

Better.

How are you sleeping?

Better.

He sits quietly. He knows he is expected to continue, but he doesn't want to talk.

He doesn't know what to say. A minute goes by. He is suddenly confused about the rules. Are they are waiting each other out, or aren't they? Have they reached a point where the first one to speak wins, . . . or loses? . . . He hates thinking this way. It must be genetic. His hands lie in his lap, fingertips pressed together. He begins to circle his thumbnails repeatedly with his forefingers. He also begins barely, almost imperceptibly, to rock back and forth in his chair. As soon as he realizes he is doing these things he stops. He concentrates on what it is he is supposed to say.

I remember once, when I was thirteen years old, I got into an argument with my best friend over something, I don't remember what, but we ended up going back and forth like we were two kings in parlay over some newly discovered continent or trade route. Through the years, that seems to have been a recurring theme with me.

In what way?

What do you mean, in what way?

What did you and your friend say?

Oh. I don't know. Something along the lines of . . .

Is true.

Is not.

Is true.

Is not.

One more than that.

No. One more than that.

Too late. I already said one more than that.

It doesn't work that way.

Yes it does.

No it doesn't.

I said yes it does.

. . . You know . . . a typical childhood argument. Preparation for adulthood.

Then what happened?

What usually happens. We kept at it until we were yelling at each other. As soon as I realized he was about to lose it, I began backing away from him. He was stronger and faster, but I have a criminal mentality. Once I was far enough away I said, Have it your own way. But always one more than you, on everything else,

forever! That's when he came at me. I had enough of a head start to climb a tree before he could reach me. It was a big tree with rotten limbs. When he tried to climb after me, I broke off pieces of the limbs and threw them at him. That kept him on the ground. When he bent down to pick up a stick and throw it back, I would say, Pick up that stick. When he would move to pick up a different stick I would say, Pick up that stick instead. When he finally picked one up I said, Throw it. He didn't throw it. He didn't do anything. He just stood there staring at me. He wanted me to come down, but I knew he would beat me up if I did. His mom eventually called him home to dinner and I ran away. That night, before I went to sleep, I said, Always one more than you, everybody, for everything, forever. It occurred to me that maybe someone as far back as the Paleolithic era had already beaten me to it, but then I thought, It seems original enough. Maybe I'm the first.

What happened the next day?

What do you mean?

Between you and your friend?

Nothing. We were fine. We were best friends.

She writes something on her notepad. He wonders what it is. It could be anything. Maybe a personal reminder to pick up something on the way home. It's all part of the puzzle, he thinks. He looks at her for a long time. She looks back at him. Steadily. Professionally. He observes her body language and finds it to be neutral, open, entirely appropriate to the situation. He wonders about his own body language. He is sitting up straight. His legs are crossed at the ankles. He looks down at his hands resting in his lap. (He is vain where his hands are concerned.) He stretches out his fingers to check his cuticles and suddenly, with an unprecedented rush of adrenalin, sees past them to the large mole hole in the middle of his lap. It is more than a hole. It is a gaping wide mouth, like the mouth on a blow up doll, shouting in pantomime for all the world to hear, Your fly is open! Hey, everybody -- his fly is open! XYZ! XYZ! His anti-mimetic conditioning fails him completely and he responds with Goofus unoriginality, Great! Just fucking great! Thanks a lot! . . . A cacophony of voices from grade school nuns, high school gym teachers, Air Force drill sergeants, girlfriends, college classmates and co-workers yells back at him, Why can't you ever remember to zip it up? He feels his face getting hot. His knees start to tremble. That is when he closes his eyes. And then, as he has done instinctively since he was a child, he systematically calms himself. First, he takes several slow breaths. Next,

he draws a circle in his mind. He turns it into it a sphere. He colors it blue and makes it shiny, reflective, like a Christmas tree ornament. He places it in empty space. He makes another sphere. And another. He makes them different colors. He places them in the space he has created. He tries to see the reflections of all the other spheres in the first sphere. He tries to see the reflection of the first sphere in all the other spheres. He imagines an infinity of reflections. He moves from one sphere to another, imagines each of them a soul, imagines an infinity of them standing together in the silence of their singular, shared destiny.

Are you all right?

He opens his eyes. I'm fine.

You seemed for a moment as if you were upset or distracted.

I was just thinking.

About what?

About things that matter. As opposed to things that don't. I was trying not to escape into thinking something mattered that didn't.

And what was that?

He pauses for a moment. Ok. Have you read T. S. Eliot? Of course you have. Everyone who has read poetry in college has read *Prufrock*. It's like asking someone if they have ever read a comic book. But for one thing, it would be a cliché. That one thing is this: with a single poem, Eliot took modernism straight to postmodernism. Almost every phrase in that poem is a deliberate reference to something outside itself. *Prufrock* is an implicit hypertext that lets you jump out of the poem to some classical reference and right back in anytime you like. When you get back, you realize the thing that sent you out turns out to have been a joke or even a pun. The whole thing is a recursive, self-referential parody of classicism and modernism both. You read that poem and you realize postmodernism is just another word for physics. The break with time had already occurred, and not just with Einstein. Once time becomes relative, you've entered black hole territory. Everything else, including pastiche and kitsch, is just a bag of tricks by comparison. Nothing is new. Everything is new. Nothing is related to anything. Everything is related to everything else. *Prufrock's* his most famous poem, you know. As far as I'm concerned, it's on a par with the first issue of *Playboy*.

I thought *The Waste Land* and *Four Quartets* were considered his most important works.

She is sharp. She could cut you.

No. Those poems are career filler. I'm personally convinced he wrote *The Waste Land* specifically for the purpose of generating formulaic essays and dissertations as a backup plan to insure his legacy. *Prufrock* was something different. It was unique. It was the breakthrough. It was a twentieth-century how-to manual on love as the frustrated desire of a middle-aged man for a beautiful young woman in a morally bankrupt society, a timeless subject, only the middle-aged man is a twenty-three year old virgin. After *Prufrock*, Eliot was more concerned about his reputation than his work. He just wanted to be liked. Sort of like Sartre after he joined the Communist Party. Anyway, in *Prufrock* there are two lines that read, *In the room the women come and go/Talking of Michelangelo*. We discussed that poem in class and the professor asked why, with all the repetition in the poem, those two lines were the only ones repeated back to back and word for word and I told him, Because they're the focus of the poem. They're the farther room. It's a love poem. He's in a brothel. Those lines are why he's there. The professor told me I was wrong and that *Prufrock* was at a cocktail or a dinner party. He insisted that Eliot would never write a poem about a brothel. I said, Why not? He asked if I had ever been to Boston. I said, No. He said that people who live in Boston don't write poems like that. He said Eliot's grandfather was Unitarian. I said, But look at Nietzsche. His whole family was Lutheran. Then he asked if anyone else thought the same way I did and no one raised their hand. I was disappointed at the time. I have since learned that in those situations, excluding teenagers and other revolutionary types, the majority will almost always side with the person in authority.

Is that what you meant by escape?

No. Not at all. That's not the escape I was talking about. *This* is the escape I was talking about. The conversation we're having right now. This escape into thinking that thoughts and words are enough. Thinking that the world is made entirely of thoughts and words. Just now, I've escaped into a conversation with you about things that may or may not be important, but to do it I had to leave something behind that was much closer to what I really wanted to say.

And what was that?

I wanted to say that this is a really one-sided conversation. I'm the one doing all

the talking. I want you to talk to me for a while. In all the time I've been coming here, I can't remember one real conversation we've ever had. I want to see you reflected in my mind as we talk. It would be so much easier to talk with you that way. I want us to have a dialogue.

I thought that this was a dialogue.

Are you telling me that you think the best possible therapeutic model is for me to do all the talking while you sit there with only an occasional question to keep me going? Don't you ever sit on this side of the desk?

Actually, yes. But that's my therapy. This is yours.

He sits quietly, his chin in his hand. There is a pen lying midway between them on her desk. He reaches forward and picks it up.

Look. Like I said, I've been coming here for a while and so far the conversation has been pretty dull. There's been no real transference in either direction that I can see. No hostility, or avoidance, or rescue behaviors.

There has been some avoidance.

Ok. But this is not avoidance. Look. Just do one thing for me. Call it a favor. Describe this pen to me. That's all I'm asking. Really. It's not about control. It's more about trust. Just a couple of sentences. I want to know what it is I'm holding in my hand where you're concerned. It may be obvious to you, but it's not to me.

She looks at the pen and says, It's a ballpoint pen. It's my favorite pen. It was given to me as a gift.

He is relieved. Thanks, he says. That helps quite a bit. I don't think that this is really a pen, by the way. The only thing that makes it a pen is that I'm paying attention to it. I'm looking at the world in front of me and then all of a sudden I say, Look, there's a pen. It's so-and-so high and so-and-so wide and so-and-so deep. And the next second it's still there. And a little while later, it's still there. From a logical point of view this pen is periodic, a series of similar events. As long as it retains its periodicity it remains a thing in itself. Its periodicity is as much a function of the ways in which I pay attention to it as it is the ways in which it pays attention to itself and to me. For example, if I give it a closer look I find out it has parts. And they are periodic, too. And every part has a name. And

even if I don't know the names, I know they exist. Somebody has named them, sometime, somewhere. As a result, this thing, this pen, has its place in the world along with every other thing that someone has decided exists, including all those things that I call myself -- sensory perception, language, thoughts, emotions, actions, habits . . . That is what time is, by the way -- the attention we pay to things. If we did not pay attention to them in the ways that we do, they would not exist as they do. They would exist, not as things, but as one and the same with the unity that is the universe. We create time by paying attention to things. Apart from our paying attention to them, time does not exist. Of all the things in the universe, time is the most purely relative. But that's not what interests me about this pen. What interests me is what you said. You could have told me things about this pen that you know we both already know. You could have pretended to tell me things without saying anything at all. Instead, you chose to tell me things that I could never have known without your telling me. When you told me that you like it, you made it important and worth talking about. The fact that it was lying on your desk was not a random act. And the fact that I'm talking with you about it is not a random act.

He puts the pen back on the desk. She relaxes a little.

He had hoped for a more favorable outcome as a result of his exegesis. He wants to feel calm, but he doesn't. Again, he clears his mind. He takes deliberate, slow breaths. He listens to his breathing: soft, a whisper entering and leaving his body. He feels the line of his lips pressed against each other. He becomes aware of the tension in his raised shoulders and deliberately lowers them, relaxes the muscles in his shoulders and back. He lowers his chin slightly and allows his upper arms to rest against his sides. His head and torso move slowly, almost imperceptibly, forward and backward with each breath. He breathes gently, moves gently forward and backward, again and again.

As if waking from a narcoleptic sleep, he straightens up in his chair and asks, What just happened? Did any of that make any sense?

Yes.

Good. He smiles at her. Would you like to see a trick?

What kind of trick?

A writing trick. If you would give me another pen and a piece of paper I'll show you.

She takes a piece of paper from her desk drawer and places it, along with two pens, in front of him.

He leans forward and takes one pen in each hand. Immediately, he begins writing simultaneously with both hands, beginning at the outward edge of the paper and moving toward the center. As both hands reach the center, he reverses direction, moving again to the outward edge of the paper. He continues this back and forth motion, until he has moved from the top to the bottom of the page. As soon as he is finished, he lays the pens on the desk and pushes the paper toward her, so she can read what he has written.

You wrote this upside down.

Yes.

It's *Prufrock*.

Yes.

Your handwriting is very small.

So I've been told.

That's quite a trick, she says as she picks up her favorite pen and writes something on her notepad.

Thanks . . . Look. Don't take this personally, but sometimes I don't really know why I keep coming here.

You choose to come here.

<Silence.>

Anything else? she asks.

Yes.

What is that?

I think maybe my girlfriend is seeing someone.

We can talk about that next time.

She smiles, sits up a little in her chair. She stands up and walks to the door. He follows her. She is wearing a close-fitting dress. He starts to look at her body but stops himself. He imagines that she knows he has had to stop himself from staring at her. He imagines that she is used to it, that it's part of the job and that she will brush it off like a loose hair as soon as he leaves the room.

There is a courtyard in the center of the building, fully outfitted with benches, hedges, trees, a fountain, and paved walkways. He always comes here after a session. He sits down in the Saint Augustine grass with his back against a tree. He can afford to spend an hour here before he goes back to work. To sit and think, or not think, as he looks around at whatever there is to see. That is the real reason he continues to come here -- to remember or imagine all or part of whatever there is see. To imagine a face in the grass or the trees. To engage in one imaginary conversation after another with one real or imaginary person after another. To say things that might change things. All his life he has done this, talked to a person in his mind about a certain thing a dozen times before actually talking to that person about that certain thing. And then reliving and revising the conversation a dozen times afterwards,. This is how he has lived his life, talking to one person, real or imagined, after another, trying to get better at it, trying to get it right. And even if there really is a person there, which there often is, talking to them in the same way he would talk to them if he had imagined them is no different than talking to them as if they are unimagined, because in some way, they are all imagined, and not only by him. Everything is mediated. Nothing is not. That is why he talks and has always talked to everyone he has ever met or imagined as if they are really there, as if they share the same close correspondences to things outside themselves as he does, as if what he is saying makes sense and what they are saying makes sense, even though neither of them may understand it at the time. And for the very same reasons, just as often, he has these same conversations without practicing or rehearsing them at all, but just saying whatever comes to mind, in the same way that a professional basketball player takes the shot, without thinking, knowing he is more likely to make it if he does not think about making it but simply goes through the process of making it. Or the master chess player who moves the chess piece instinctively, having played countless variations of this one game, having an intuition born of experience that tells him that of all the many moves that may succeed this move and the seemingly infinite moves that may succeed the next move and the one after that and the one after that, that this particular move is the correct move, and he knows it without knowing with any specificity why it is the correct move, or how the game will turn out, only that he has won most of the thousands of games

he has played by doing this, understanding with absolute certainty that he has won, several moves before he or anyone else can prove it. That is how he has lived his life to this point, by thinking and not thinking, believing all the while that each choice is the correct choice. It is only recently that this way of being in the world has failed him, has taken on a separate identity, inexplicable in its inability to easily transform itself to and from its opposite. He doesn't believe in chaos without order. Chaos is a combination of symmetry and randomness, a form of order beyond present comprehension. Randomness can no more exist without meaning than order can exist without chaos. Chaos and order are choices that we make, just as thinking or not thinking are choices that we make, each choice the same choice, the choice that every person makes each time a choice is made. The choice to see one thing and not another, to think one thing and not another, to do one thing and not another. It is impossible to escape purpose or meaning. Purpose is everywhere. It is equally impossible to escape chaos and randomness. Randomness is everywhere.

Something in the grass catches his attention and he reaches down to pick it up, holds it directly in front of his face. At first he thinks it might be a Lilliputian, someone to talk to, but it turns out to be a twig. He examines it closely, the sleuth in him hoping to determine by what means it found its way here, first between the leaves of grass and now between his fingers. It is small, broken on one end but not the other, with what appears to be a bud at its tip. It has a bud scar in the middle. Its bark is intact. It is dried out. He cannot tell in what season it might have fallen. Perhaps a bird snapped it with its beak or dropped it on its way to its nest. Perhaps the ice and wind beat, bent and finally broke it. More likely, when it fell it was part of a larger twig or branch that was eventually hacked to pieces by a lawn mower, making it small and inconspicuous enough to remain ignored all this time, to be left to its own devices as long as it didn't disturb the carefully constructed atmosphere of the courtyard. But now it has been noticed. And picked up. And examined. I'm no different than you, he thinks to the twig. We're like Hansel and Gretel, either following or leaving behind us little pieces of ourselves as we wander deep into the moonlit forest. That is our destiny: to follow things, even the smallest of things, and try to remember in what order we found them should we find it necessary, for whatever reason, to backtrack. Perhaps the attentions we pay to things in this world are not only the result of the comfort we gain from remembering them, but more importantly, the excitement we gain from discovering that we have remembered anything at all. In the end, isn't that the sum of what we are -- the countless particular attentions we've paid to things in a life in which each thing exists only as a result of the attention it is paid? Isn't that what ambition is -- the desire to become, in time, a set of footprints on a path that someone else will follow, the desire to find a

prominent place in the canon of things that matter, to be remembered as the person that our mind has made us -- a maker and member of lists? Beginning with the circumstance of birth, place and time, we choose a named path through the larger world of circumstance, moving from one point to another, calling each of them by names that someone else has given them or that we in turn have chosen for them. It's too bad the forest floor is so littered with detritus that you can hardly tell one path from another anymore. Thank god for biodegradation.

Hey!

There is a voice coming from somewhere deep in the wood.

Hey!

In a single instant his soul suddenly and violently re-enters his body, jerked back after having been stretched like a rubber band across some interminable distance. With great effort he remembers where he is, focuses on the person addressing him. Less than two feet away from his nose is another nose and behind that nose is a face. Sitting cross-legged in front of him is a young man, twenty something, smiling, thin, dressed in a golf shirt and slacks, with close cut white hair and perfect teeth.

What are you doing? the young man asks. Meditating or just zoning out?

Neither. Staring at this twig.

So, were you on the trail of something?

I suppose.

What kind of trail? A hiking trail, a jogging trail, a happy trail, or a trail of tears? I'm an expert on all of them, by the way. I can give you advice if you like. I know things, . . . for example, that you're an outpatient.

How do you know that?

Because you're wearing a suit.

How do you know I'm not a doctor.

No doctor would sit out here under a tree staring at a twig for five minutes. Be-

sides, you can't make money sitting under a tree. Not even Buddha could make money sitting under a tree. Now Ralph Waldo Emerson could probably make money sitting under a tree, but you're not him are you?

No . . . So are you a psychiatrist or a patient?

Neither. I'm a psychiatric social worker.

That's interesting.

No it's not.

Yeah. Well, I need to get back to work.

What kind of work are you getting back to? . . . Don't get mad. I don't really expect an answer. I am, after all, a professional. You've got your rights. On the other hand, if you're going to sit under the Bodhi tree in a place like this, you've got to expect questions from the occasional supplicant.

Is that so?

I don't know. I guess not.

I'm a computer scientist.

There you go. I knew it. I knew we had something in common. Although I'm a social worker, I too have an affinity for philosophy. No French continental deconstructionist philosophy for me, although I must admit, having read all their stuff, some of it makes sense. Even so, I've decided to stick with good old American analytic philosophy. Mathematics and logic. Physical science. Don't worry. I can keep up. Einstein, Turing, von Neumann, Shannon, Chomsky, Feynman. I've read all those guys.

Are you sure you're not a patient?

I'm your alter ego. I'm the spirit of the twig, an angel sent to look over you . . . Just kidding. Listen, we're all patients in one way or another. It's problematic, right? So. What exactly do you do?

I work for a computer chip manufacturer. I design software for programmable chips.

Programmable chips?

Silicon chips that have a generic digital substrate. You load the circuitry in as software as you need it. That way you use a minimum number of circuits and a minimum amount of energy in a minimum amount of space.

Wow. That's cool. What do you do with them?

Use them for different things. Like radio frequency based identification. You can attach a chip to every unit of production and keep track of it no matter where it goes.

What do you mean, every unit of production?

Everything. Everything that's manufactured and everything that makes, holds or transports anything that's manufactured. Containers, pallets, packages, products, individual parts of products. Everything.

What about people? What about plants and animals and chromosomes and things like that?

Yes. Those too, eventually.

Man, you're the devil! You're 666!

No, I'm not.

Yes you are.

No I'm not.

Listen, I know what I'm talking about. First, you're renaming all of creation. Then you're keeping track of it. And then you're controlling it. You're trying to be omniscient and omnipresent and omnipotent all at the same time. You're architecting Armageddon. You're Big Brother's right hand man . . . Wow. Here I am sitting across from a guy who's rolling out the red carpet for the Antichrist.

No I'm not.

I'm not arguing with you. I believe you. You know, it's even more interesting in an ontological sort of way if you don't believe or know that you're doing it. It

makes you karmic celebrity material. An instrument of Fate, so to speak. It puts you at the top of the all time religious myths hit list, the top ten religious myths of all time. You know, . . . myths. God the creator. Man as Hero. You know . . . the universal truths. There are more myths than you can shake a stick at, but some of them are universal. No matter where you go, there they are. And what you're doing puts you right at the top.

What are you talking about?

I have to tell you, I live for this stuff, but I can almost never find anyone willing to listen. You seem like you might. If I just tell you their names, they won't seem very awe-inspiring. They need to be part of a story. They need embellishment.

<Silence.>

Great. . . . Ok. Look. Instead of doing a top forty countdown, we'll just start at number one. That way we can stop whenever you want. . . . Ok. Number one -- creation. Creation boils down to, now you see it, now you don't, only in reverse. Something from nothing. Not something from something smaller. Or from something far away. Or from something that you can't see. From nothing. No slight of hand allowed. Once you get the first something, then it's a lot easier to rationalize everything that comes after. It's easier to imagine Athena popping full-grown out of Zeus's forehead than to imagine her popping full-grown out of a scientifically controlled vacuum. After you get started, things are not so much created as translated or transformed, like water turning from ice to water to vapor. Or dust turning into Adam. Or matter into energy. Or energy into matter. Once you get past the initial creation, everything else is Creation with a little "c." The Greeks understood this better than anybody and approached the problem directly. In the beginning was the Void out of which came Eros and Earth, desire and a place to do it. Anything else begs the question, If god made everything, who made god? The Sumerians and the Hindus start with a primeval sea. The Egyptians boil water. The Chinese and Japanese hatch everything from a great, black egg. The Babylonians, Hebrews and Sikhs have an all-powerful deity that is responsible for everything. These days we like-minded individuals have general relativity and quantum mechanics as our principal authority on the question. For a long time, everything in science seemed to argue against Creation until the Hot Big Bang came on the scene. I know you probably know all this already. But did you know the Big Bang is the leading contender for a Theory of Everything? It explains everything from about one hundredth of a second after the Big Bang until now. Everything before that is still waiting on a self-consistent explanation for quantum gravity, which is just another word for gravity. But given the Big Bang,

the general consensus is that we're about fourteen billion years old and that we may actually live in an infinite, open universe. I call that good news, myself. And there's a very interesting corollary that goes along with it. Since all the galaxies appear to be moving away from each other at an increasing rate of speed, this universe may not be part of a cyclic process at all, but instead may be a one time only thing, eventually ending in a cold, vast darkness otherwise known as *The Void*. What do you know? Right back where we started. Now that I think about it, maybe it still begs the question. Is the Big Bang real or simply the current state in some conceptual chain of cause and effect leading back to the Greeks, their cosmology and their math? Is our concept of the universe species specific, or could it be arrived at independently by a group of sentient aliens who never heard of Euclid? We may never know. And even if you do start with the Void, and by the Void I mean the *real* Void, that is, *absolutely Nothing*, which makes the most sense to me by the way, where is the cause and effect that gets you from Nothing to Something? What's on the other side of Nothing? If there's nothing to change it from being Nothing to being Something, how come it's not still Nothing? There's no way around it. Creation is the Big One, the ultimate myth. If you can accept Creation as a possibility, you can accept anything. I'm going to keep moving. Here's another one. Paradise. Paradise is one of my favorites. I know it like the palm of my hand. In paradise there are no arbitrary divisions between creator and created, and as true as this is, there is also no specific requirement for any particular type of uniformity or diversity. Paradise can be as diverse as you want it to be. Or as boring. When it's all said and done, the definition is simple: You in direct communion with all that is good and perfect. I'm not making this up. I'm being historical, I swear. The Garden of Eden is an easy example. Everything is perfect. Everything is beautiful. Adam and Eve are running around naked and don't even know it. And although theologians are divided on this, there is a school of thought that believes that they were having sex all the time. Paradise in this case is like being a kid in a candy store who's been living in the candy store for several hundred years. You can have whatever you want whenever you want it and you can do whatever you want whenever you want, but you've already done everything a thousand times. Except for one thing. And of course you end up doing that one thing and all of a sudden there's hell to pay. But you get another chance -- not here on earth, but in heaven, the other paradise. The paradise that almost nobody gets to report back from, a situation that results in so much conjecture that it becomes almost impossible to get any consensus on what it's like to live there. You have theories ranging from a White Light into which you want to disappear forever in an ecstasy of bliss on the one hand, to a place that is much like earth except that god and the angels live there and you can see them, and all the houses and streets are made of gold and no one ever gets sick or hungry or depressed on the other. There is one sig-

nificant difference between the two paradises, however. In the earthly paradise you can have or do almost anything you want and you never have to feel guilty about it. In the heaven paradise, you're a lot more respectable. You're going to live forever and you don't mind doing it as a retiree -- cool, calm, collected, at peace and at one with yourself, not so caught up in things that you easily lose your sense of perspective. Totally self-actualized . . . One more thing. Paradise should never be confused with utopia. Utopia is misguided. It assumes paradise can be created here on earth, usually politically. Human beings are genetically programmed to form hierarchies and are competitive by nature. The only reason it worked for a while in The Garden of Eden is because there were only two people: Adam and Eve. God's not a person. He's perfect and incapable of giving anyone bad advice. On the other hand, the minute the Serpent showed up, who, although not exactly a person either, is portrayed as a born troublemaker, it was all over. The only remaining possibilities for any kind of perfect place are either in a heavenly paradise where everyone is enlightened and god is completely in control, or in your head if you can reach the point where you believe that everything is already perfect just the way it is. This is all pretty pedagogical I know, but if you're willing to listen, I'm willing to talk . . . I can tell you're still listening. I'll do one more, Rebirth, and then I'll stop. . . . Promise. . . . One of the first things you pick up on when you reach the age of accountability is that everything living dies. It's born, it lives and it dies. Then you hear about the soul, that the soul is eternal, that it came from and returns to god, that it maintains an existence independent of the body. Or maybe you're raised in a way that doesn't require you to think about what happens after you're dead. All you think about is the fact that you're here right now, and your job in life is to be as aware of that fact as you possibly can. Or maybe you believe that you have to be born over and over, gradually progressing toward an eventual release from life and death. Or you can decide that nothing happens after you die. You're just dead and that's it. A lot of people who believe that also believe in their chromosomes. Since chromosomes don't die as long as you're able to make a baby, a baby becomes a way to have your genetic self live on in another person. And although that's a great thing *I think*, it doesn't change the fact that your body is going to die and decompose. Classic entropy. When that happens, about two-thirds of the words you normally use to describe yourself will no longer apply. And as for the rest, once you remove the memories, whatever there is of you that's left over bears very little resemblance to the you standing in front of the mirror in the morning. Or maybe it does, I don't know. Nobody can say what happens after you die. Death is a singularity, just like conception, just like the Big Bang. No one can say for sure what happened one one-millionth of a second before they got here. And no one here can say what happens one one-millionth of a second after you realize you're not coming back. That's a strange thing about this particular myth.

What most people don't realize is that if rebirth or immortality is a myth and not provable, then the anti-myth is as much of a myth as the myth.

That's interesting.

Really? You think so?

I've really got to go.

But I haven't even gotten to the Apocalypse.

I'll come back.

No you won't.

How do you know that?

Domestic Interlude

At first they plan to go out for dinner. She in her black silk dress, her eyelids painted blue, her long hair pulled up and fastened with pins. She is very beautiful. As they are backing out of the garage, she says she would rather rent a movie and order pizza. They are the best dressed people at Blockbuster's. They rent *Amelie* and *Das Boot* and call in for a pizza on the way home. Fifteen minutes into *Amelie* she falls asleep on the couch with her head in his lap. He presses the mute button on the TV. Luckily, the movie is subtitled. After an hour his knees begin to ache. A little later his legs go to sleep. He tries to keep his body very still, but eventually he closes his eyes, leans his head back into the cushion and sleeps. He dreams that she wakes up and lays him in her place and makes him comfortable. He wakes to find himself sleeping on the couch with his shoes off, his head on a pillow, his feet covered with a blanket.

Have you ever noticed how in the course of a single moment you can find your attention as focused on the most arbitrary and inconsequential things as if that thing were the terrible and awesome, wholly perfect face of god? It is easy to do when looking at a newborn child, or death, or some terrible event in nature, or some subtle nuance of motion, light and sound into which we pour all of the love, or hate or grief of a single moment. Sometimes the ecstasy of sensation is enough. It is less easy if something as simple and familiar as a pizza box, or a

shoe, or a blank spot on the floor attempts to capture our attention in the light of its singular gaze, so that we are forced to see it for what it is and has always been -- the god Siva dancing on the waters of chaos. That is what is happening now as he stares at a patch of carpet weave, the toe of a woman's shoe, the intersection of the two. There is no breaking sea, or deepening sky, or wind rising and falling, filling spring trees like lungs with which to manufacture time. There is no time. There is instead the slow silence that precedes her touch and touching her -- simpler, better than time.

In the eighth grade he had a crush on his English teacher. One Friday, after all his schoolmates left the classroom, he walked up to her and recited *La Belle Dame Sans Merci* from memory before turning and leaving the room. When he got home from school, he found out she had called his mother. The moment his mother brought it up, he became frigid with terror. He had possessed a raging erection while reciting the poem and didn't know whether or not his teacher had noticed and, if she had, whether or not she had told his mother. Luckily, his mother didn't mention anything about an erection, and she didn't say anything to his father, so he didn't get into too much trouble, except for having to spend one Saturday morning at a school sponsored program on human sexuality where he watched films about human sexual reproduction, venereal disease and the dangers of smoking marijuana. Later, his English teacher went out of her way to make sure he got one of his poems published in the school yearbook.

He is reading a novel. It's the first one he has read in months. The first time he read this book he was nine years old. He was in his bedroom with the windows open. The early morning sunlight made stripes across the bed, the floor and the wall and he could hear mockingbirds and smell four o'clocks. It was a time before he knew the meaning of cynicism. This is a different time. This time around, he is sitting up in bed with a night light on. There is a beautiful woman sleeping next to him. The room is rich with smells. He is happy. You want to hear more details. Why? They are always the same details. Ok, here is one more detail. Of all the opening paragraphs of all the stories he has ever read, this is his favorite: "Call me Ishmael. Some years ago -- never mind how long precisely -- having little or no money in my purse, and nothing particular to interest me on shore, I thought I would sail about a little and see the watery part of the world. It is a way I have of driving off the spleen, and regulating the circulation. Whenever I find myself growing grim about the mouth; whenever it is a damp, drizzly November in my soul; whenever I find myself involuntarily pausing before coffin warehouses, and bringing up the rear of every funeral I meet; and especially whenever my hypos get such an upper hand of me, that it requires a strong moral principle to prevent me from deliberately stepping into the street, and methodically

knocking people's hats off -- then, I account it high time to get to sea as soon as I can. This is my substitute for pistol and ball. With a philosophical flourish Cato throws himself upon his sword; I quietly take to the ship. There is nothing surprising in this. If they but knew it, almost all men in their degree, some time or other, cherish very nearly the same feelings towards the ocean with me." . . . I cannot write like that and neither can my protagonist. But he can comment on it: "If I were teaching in a liberal arts college, I would probably say something to my students along the lines of, What does Ahab represent if not corporate capitalism and the entrepreneurial spirit at its worst? And what does the Whale represent if not nature and the international rule of law? The crew of the Pequod is the middle class, always footing the bill while at the same time never having any real say in the executive decision making process. The moral of the story is that it's not ok to want to make a lot of money if you have to either enslave everybody or get everybody killed to do it. I myself am not a violent person, but I am in favor of the Robin Hood approach to income distribution: The poor should sue multinational corporations whenever possible. As hard as most of them work, they deserve, if not more, at least not less of whatever it is that corporate executives end up getting as a result of their efforts. Heads, wealth and power. Tails, prison sentences. Sometimes the only real talent that a person with money has is the talent to get his or her hands on even more money. If I had tenure, I would say something entirely different, something having to do with the Mind of God, the unity of all life and the immortality of the soul. Of course, I'm pulling all of this out of my ass. I have no idea what I would say. None of this has anything to do with Moby Dick or its opening paragraph. Still, it is a great opening paragraph. There are other opening paragraphs that are almost as good, but I can't quote them here because they're under copyright and lawyers will immediately threaten me with demand letters that tell me I have no right to use other people's ideas without their permission. These bastards would copyright the letter "A" if they could. I have friends who are lawyers so I know it's nothing personal. It's part of their role in the "brotherhood," a not-so-secret society designed to keep things as fucked up as possible, whether it's business, art or politics. There is a lot of money to be made in keeping things fucked up and they're just the guys to do it. Along with bankers, politicians, priests, ministers, mullahs and military types they're the ultimate mediators. If you think that I'm being critical of certain types of people, I guess I am. I don't know why, though. Some of my best friends are lawyers and much more virtuous than me. They are exceptional in their talents, enlightened in their thinking and selfless in their support for the underdog. One of them even went to jail once, rather than allow the police to enter the home of a client without the proper, duly authorized documents. Now that I think about it, a few of them are some of the most wonderful human beings I know. I can think of many categories of people to which I belong that are not

more virtuous than these. Go figure.”

It is around 2 am when he decides to go to the kitchen table and write.

She sleeps so deeply
her eyes do not move
behind her painted eyelids.
She would rather sleep than dream.

*Upon a new bed
the moonlight shines -- light enough
to make a painting
of leaves, grass and winter frost.
On another bed*

*a woman cries quietly
to lessen the tears
of nearby sleeping children.
A different world
now, than that of clouds and rain.*

He titles it, “*The Bridges of Madison County meets Ise Monogatari meets Our Town.*”

There is nothing they haven't done to please themselves and each other. They've put their fingers, toes, tongues, noses, his penis, her nipples into every orifice and over every inch of skin on each other's bodies. He has kissed and nuzzled and licked her from the top of her head to the soles of her feet more times than he can remember. She has done the same to him. She has blindfolded him, tied him to the bed and, while consulting a magazine, dripped melting wax on his chest and stomach, poured crushed ice over his crotch and ridden him like a cowgirl. He has come up behind her while she was rinsing vegetables in the kitchen sink, lifted her dress, ripped her panties at the waist, bent her over the counter, entered her from behind and, holding her hands flat on the counter in front of her, fucked her as hard as he could, coming after only a few minutes. She has put her face between his legs in the parking lot of a restaurant and sucked until he came hard, groaning and heaving in deep breaths, even as people entering and leaving the restaurant passed next to the car. He has pushed his hand inside her. She has pushed her hand inside him. He has rubbed her feet while she lay on the couch and after she was completely relaxed, put his face and one hand between her legs, doing whatever he could to please her. They have

stood face to face for long periods, kissing endless small kisses while they slipped their hands down each other's pants. He has masturbated in far away hotel rooms fantasizing about her. She has come naked into the bathroom while he was soaking in a hot bath, sat down between his legs, leaned back against him as he put his arms around her and lay there with him, without speaking or moving, until the water turned cold. He has come into the bathroom while she was soaking in a hot bath, washed her feet, her breasts, her back and shoulders, shampooed and rinsed her hair, toweled her off and then brought her a glass of water to drink. Once they are asleep the first thing they do is to move away from each other on the bed. Then one of them will reach out to touch the other with a hand or a foot. Gradually, they slide toward each other as they bend into spoons and nestle together, her arm over his belly if she is in back, his hand held gently against her breasts by her hand if he is in back, the one in back breathing in the scent of the other. Does he make her happy? He sometimes thinks he does. As when she does something to tease him, unbalance him, put him off a little, laughing at him the whole time, knowing that this is what women sometimes do to make their lovers crazy, to make them want them more, to make them love them. On Saturdays they sometimes go to yard sales. She usually wakes up first. They shower together, drive through a McDonald's for breakfast. She was a good catholic girl, raised to believe that sex and love were one and the same, that true love was to be had with one person in a lifetime. She believed this when she was young and continued to believe it even after her first love left her, continued to believe it even after she found another who she left for reasons having nothing to do with love or marriage, continued to believe it from one love to the next, believes it even now. They find a garage sale filled with items gathered from an attic. She buys two ruby crystal glasses. He buys a box filled with books, papers, a novelty postcard and a chess set. She looks in the box and smiles at him, You are so like yourself. Do you know that?

II

St. John's Monkey Hour

You start by waking up. It is hard. It is always hard at first. It is the middle of the night. Perhaps it is afternoon. It is difficult to tell. You tell me. There are no windows where we are. Maybe there are, although I am sure there are not. It is hard to remember. The place where you would go to remember is already occupied by another thing. The thing you do to make it less hard, so you can go back to sleep, at least for a little while. It only works once. Sometimes twice. Where is my gift basket with the apples, bread and olives in it? I ask myself in my dream. It was right at my fingertips the last time I looked. I like that basket. It is made of plastic and is smooth on the inside as only a plastic basket can be. It is someone's old Easter basket. It has been recycled as a gift to me or someone like me. I am sure of it. It is a form of penance not to be able to find it. I am not blind. It is less that I am blind than that I cannot see to do anything in this strange darkness, a darkness arrived at, not through an absence of light, but through the addition of something new, mixed together with light and with itself, the two things making it more and more difficult to see anything at all as the galaxies grow dimmer and farther apart. Maybe there never was a basket. Did I eat bad bread instead? Something moldy perhaps, leftovers from an earlier gift? It would not be the first time it happened. It would not be the first time it happened and I or someone else wrote about it. A religious and totally unexpected turn of events has occurred. There is a religious event here somewhere. It is hiding. The fact that I cannot see it does not mean that it is not hiding. There is no other explanation. I say, Come here, but it will not come. It needs time. But there is no time. At least, not yet. Not for an event such as this. It does not even know what it is waiting for. Without time, it has no way of knowing anything. I am the only one willing to tell it what it is and it will not listen to me. It has never even heard of me. Me or anyone else I know or have heard of. From a certain point it all makes sense as long as you remember not to move too far away from said point. The further you move, the more the sense fades into non-sense along with everything else. That is always a good time to move to the next point. Begin again. Over and over. An infinity of random points, each of them surrounded on all sides by friends and relatives. They tell each other, This will all make sense soon. On and off. Above and below ground. Soon, very soon, it will become holy. You will see. We will all see.

There are three things to pay attention to in this new century. One is the market. The free market for attractors. Between, above and below atoms and molecules with their four forces, everything else is wanting, children and their toys, men and women, men and men, women and women, women and men, all the tragicomic faces of the five elements. The fire is in the mind and the loins are in the fire. The big brain and the little brain wrestle and sweat together in the game room in front of the TV. It is hard to pay attention to everything at once. After so many years the solitude wears thin. It desires to be as specific as possi-

ble. Standing side by side, or perhaps facing each other, are two men. One of them has a long robe and sandals, something on his head. The other has something expensive on his wrist, or is it around his neck? They belong together, that one thing is certain. One is the father of the other. They walk alongside each other down one hill and up another. There is a woman with her face covered. The smell of cinnamon surrounds her. She is waiting for them in the turn of the road. She offers herself to them. She takes money and a keepsake from one of them for her favors. A promise is a promise after all. She intends to make him keep his promise, a promise he has already broken. Something for nothing. Where is the profit in this? What does that even mean? Everyone does this. Everyone says this. How different from a dream this is, this walking along the road with my father, or is it my son, discussing the many ways in which societies differ? How some of them have one man, almost never a woman, at the top, giving directions, making history and if not history at least books, newspapers, magazines, television, movies and money in their own image, the image of the great man with a name that someone is bound to remember sooner or later. How he dressed in such and such a way. How he carried himself. What he said. Perhaps he had a pet of some sort that he was fond of and he took with him everywhere, knowing that the right animal is the perfect image of compassion and that people will forgive almost anything for the sake of one's pet. Not an elephant or an alligator or a hamster, but a dog of some sort, a Scottish Terrier perhaps, or a German Sheppard. Given this, what other societies are even possible? Whatever they may be, whatever their intentions, they always come to this, a man and his dog, loyal, steadfast, even after death refusing to leave his master's side. That is the world of men, says my father to me as we walk up one hill and down another, alongside the rocky beach where you can see the white crests of waves lapping the shore, phosphorescent in the gloaming. Identity management is critical at times like this. There are so many to choose from, there is no other remedy than to keep a list in your pocket, and if not your pocket, at least in your sock, under your heel inside your shoe, where no one will think to look if they frisk you, searching for valuables. So many images come to mind it is impossible to list them all. Intent is everything. Do you try to make yourself as unpalatable as possible in an effort to eat or not be eaten, to present yourself in the form of leaves, twigs, tree bark, stones and dirt, or do you mimic something utterly desirable, the most valuable thing in the world, a diamond, a koan on the head of a dead cat, or even an angel, in order to attract your prey? I picture in my mind an insect of the order Neuroptera, eating aphids at a languorous pace, covered with detritus of every sort, a house in a good neighborhood, a car, two cars, one of them an SUV, good credit, a club membership, investments, a genealogy reaching as far back as church and government records will allow, the right DNA, an education, a profession or occupation with notable prefix or suffix, a six-figure income, a sta-

ble marriage, the right friends, good looks and a sunny disposition. I am not bitter, although I have even been told on several occasions I taste of almonds. I look in the mirror. There is no mirror, so I look in the water, not the froth at the edge of the sand, but the calm of a nearby tide pool. In the shallow darkness I imagine my reflection. In my mind an image stares back at me, filled with curiosity, one eye open, one eye squinting, its mouth gaping a little. The obvious keen intelligence in its face could easily be confused with that type of idiocy whose chief symptom is the tendency to focus with such harmonic intensity on a single thing that it often forgets to close its mouth in time to stop the drool from escaping down its chin. There, I have said it. There is a mole on its face, with several long hairs growing out in an arc like the long leaves of certain desert grasses, or the multi-colored filigrees that emanate from fireworks displays. Although I am not Mandarin, I must admit they are magnificent. They are not to be trimmed, or plucked away, but admired, in a quite, studious way by some, erotically by others. The mole is a planet with its own orbit, with a landscape not unlike that of the dark side of the moon. Gravity can be trusted to keep it well within the larger sphere of one eye and a nose that is, to say the least, august, pedimental, fit to crown the temple of a Roman emperor, a nose through which only the elect might enter the inner chambers. I will stop there. I am not proud. I am, in fact, humble, although I try to be objective both in my observations and in my sympathy for those who, like myself, choose to see their own true nature, not in a mirror, but in mind. I myself have no mind. I am nobody, no one, for I have heard God's voice and know my fate, to struggle constantly with myself, my pride, because of it. It is because I am humble, especially for the sake of others, and proud for the sake of stupidity, that I do what I can to put the best possible face on things. Where is the Other, the one who was standing near to me only a moment before? I say this in the full knowledge that I am being hierarchical in my pursuit of the facts. The Other is sitting on a rock nearby, smoking a cigarette. The Other is picking its nose and checking the tip of its finger intermittently. I love the Other and the Other loves me. At the very least, we are friends. I would like to think I would gladly sacrifice myself for its well being, but I know from experience that I am not capable of stepping between it and a stranger, especially when it has thrown a drink, still inside the glass, at the stranger's lap in a strange bar in a strange city. I am, however, capable of accompanying it headfirst into the street afterwards. That has some virtue, surely. I attribute the behavior on both our parts to dehydration. We never talk about it. We do not talk much about anything. We confine ourselves to gestures, sensations and intimations on the two. Intimations on the cigarette, or the tip of the Other's finger or the finger's potentially exotic cargo, for example. The real distinction between myself and the Other is that I can never tell when I am boring, yet I can always tell when the Other is boring. The moment it is boring, it disappears from

view. Like a stone passing through the surface of a pool, I have either to content myself with the ripples that remain or turn my attention away entirely, towards some other fascination. Right now I am looking at the night sky, or is it the ceiling, and thinking about the long panorama of human history that has preceded me, the high thoughts, the dreams and ambitions of those many people who with their last breath exclaimed, What time is it?, or, It hurts, or, I'm scared, or Don't forget to . . ., and so forth and so on. That is the real source of history, the simple, daily journey into whatever long night we all come to share, not as an Other but as ourselves. That is the true measure of my empathy. I want to walk in my friend's shoes, for I have none. That is something we could share. We could take turns wearing them. We could wear one shoe each. We could alternate. I could wear the left shoe for awhile and then the right. I would rather have them both, but that is unlikely. Our feet are not even within two sizes of each other. That is no matter. I want them. I could try to take them by force. I must be careful even thinking such thoughts, for if my friend suspects this, my friend, my beloved Other, may peremptorily strike me down, unconscious even, while I am at my most vulnerable, sleeping, or worse, squatting behind some reeds, concentrating on my bowels. Maybe that is what my friend is seeing on the tip of its finger. My selfishness, my greed and who knows how many other failings, both in character and logic. Get on with it, I tell myself. With what? a voice answers into my other ear. You know what, the purpose of our disputation, for it has some purpose, and if it does not, then that will be its purpose. We will take a vote once we are done. To begin with, I do not hate the French. It is not entirely accidental that they placed the Little Prince on their money. I adore them for that. They have taken relational attribution to its logical and terminal conclusion. Everything is random in its relation to everything else. Every statement, declarative or not, can be deconstructed, not only into a genealogy of language, which is boring, but also of politics, which is also boring. If it were not for this simple fact, I do not think I would have anything left to say. I would be entirely without philosophy, certain of nothing. How do I know these things? I have seen them in my dreams. I have seen, for example, a bicycle. In one country I know of there are almost as many bicycles as people, since the majority of people do not have cars and would rather roll than walk their way to wherever it is they are going. In another, imaginary country, a lost continent actually, bicycles are very rare, since the people in that country live both on and under the water. In my country there are fewer bicycles than in the first country and more than in the second, one of them the lost bicycle of my lost childhood, blue, to which I attached a parachute, rolled up tightly and held by a string as I peddled hard as I could, hoping to simulate a dragster. Instead, I simulated a bicycle wreck as the parachute opened and the bicycle stopped and I did not, and the bicycle and I flipped end over end together in a spectacle of hubris, physics and humility. I say humility, for it was there I

learned the physical limitations of my testicle. I would like to say that it still serves a masculine purpose, that I have seen it, well preserved and on display in an art museum, or that it has found its way to a sacred reliquary somewhere, or that it was dried out, ground to powder and put into an amulet or charm to sooth a grieving heart. I will say none of these things, for to be true to my beliefs and my rectum, both packed tight with irony, I must confine myself to this one simple statement, I love language. It is language that has given me the chapter titles for my Book of Man, an exegetic monograph subtitled, I Am Not Feeling Myself, Lately: 1) Identity's Self-Identity, 2) Body, Mind and Soul, 3) Physical Identity, 4) Virtual Identity, 5) Analytic Identity, 6) Transactional Identity, 7) Artificial Persons (Profiles and Proxies), 8) Schizophrenia, 9) Love and Death. I find it much easier to list the chapter titles than to write the book.

The night sky is hieratic. In it I can see letters and symbols of every color, written with a hand well-practiced in calligraphy. They surround a red moon, a harvest moon, in ever larger concentric circles, overlapping each other, filling all of space with their text. I cannot understand any of it, so I will have to make something up. I kneel down for no other purpose than to feel the sand beneath my hands. I pick up some of it, pinched like salt between my fingers and distribute it evenly over the palm of my other hand. I try to count each grain by wetting a fingertip and touching it first to the sand in my palm and then to my tongue where I count the grains before I spit them out, repeat the process. At some point, I get a single grain caught in my teeth and lose count. It is a stupid, futile plan and not the first time I have failed in it. I had hoped to count the number of grains of sand in a pinch, use that number to calculate the number of grains of sand on the beach and use that number as a way of remembering my having been here at all, beneath this night sky or ceiling, filled with its beautiful, textual light. There must be a better way. I reach into my pocket for something to pick the sand out of my teeth with and find a folded up piece of paper. I do not remember this piece of paper. Where did it come from? Did I steal it from the pocket of a drunken sailor in an alleyway? Did I rip it from a library book? Perhaps I just invented it. Yes, it is an invention and since I cannot read it in the dark I will have to invent it all over again. I will call it, A System and Method for the Creation of Quantum Digital Logic. It will have purely random events as one form of input and traditional, fully deterministic binary signals as the other. The logic gates themselves, AND, OR and NOT, will be arranged in various combinations until they are able to provide true random probability with any degree of precision. The result will be a hybrid quantum/digital logic. My invention has a single picture on it that looks very much like a picture I have seen in another dream, a dream in which a man showed me this picture and when I asked what it meant in practical terms said, What does this mean in practical terms? It means it is possible to include a fundamental principle of quantum

physics, random probability, in the construction of well-formed statements in any and all languages, both human and computer. It means that quantum events exist at all levels of reality. It means that language becomes the virtual image of the world, a universal poetry for the never ending creation of metaphor. It means that hierarchy and equality are the two poles or dominant countervailing forces within the social order and will always and forever seek equilibrium or else be in conflict, whichever way you want to look at it. Having said that, he bought me a cup of coffee and as we sat outside the bookstore where I had just made his acquaintance finally admitted, I am not sure what it means. The picture on the paper looks like this:

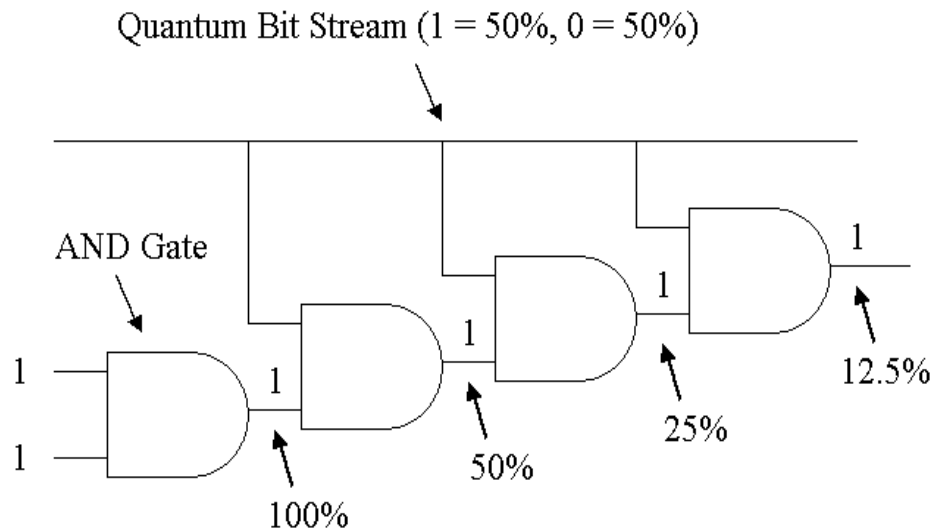

This is the means, the machine, by which I will recover my lost childhood. It is a better thing than memory. For my part, memory is no more than a history of what is best or bothering me at the moment, in turn a concatenation of mostly pleasant thoughts. Please do not ask me to remember them for you, even as an example, or to prove that I ever had them in the first place. Remember them for yourself. Remember that such distinctions are raised from the dead in order to be dismembered. Remember also that the ability to do such a thing is no great privilege. A postmodern poet said something similar, I think, or would

have, if there were such a thing as postmodernism. Modernism, with or without a post, is just another word for the act of trying to do something that captures the act of moving, not from the past into the present, but from the present into the present. It is not as if the past never happened or the future never will. It is that the present is that point at which all things converge. The question of time is finished. Time, the most relative of all things, permits us nothing. We permit time. No longer the end of History, the present is the beginning of memory, of recognition and of choice. It is not possible to observe any new thing without an act of memory. It is also not possible to act on our observations without making up, out of thin air, the next moment, and the one after that, and the one after that, as all possibilities collapse again and again into the certainty of knowing one thing and not another, seeing one thing and not another, choosing one thing and not another. It is this combination of memory and desire, of pulling the next moment out of nothing and nowhere that we call free will, aka modernism. And if modernism is free will, what is postmodernism? More free will.

I need a fresh start, but how? I began with a room, as does everyone else. A room, a knock at the door, and the next thing you know, there you are. But things have changed since then. These days I desire something with a sweet savor, not for myself of course. For a friend, always for a friend. My friend is languorous, lying on a divan, clothed in robes and bare feet, reaching over to dip fingers into honey and leave them there as if confusing the honey bowl for the water bowl, in which float rose petals for the girls and mint leaves for the boys. I feel obliged to drink my water bowl, filled as it is with rose petals, if only to save my friend the embarrassment of having to admit a mistake in table manners. Not stopping there, I reach to drink the water bowls of those to either side of me, even though the one to my left has already dipped its fingers and the one to my right appears to be dipping its napkin in and using it to clean out its ears. I have so many associations of so many people with so many smells, tastes, sounds and textures that even this adds nothing to my repertoire. I have gone so far as to compile a book of people, a Chinese menu, expressing in finite terms the variety of human possibilities. I would like to think that more than this is possible, but people seem to prefer it, to insist on it. Excuse me, what time is it? one will say. Another, What do you think about last weekend's game? Still another, You need to diversify if you expect to see any reasonable rate of return in this market. I do not fault them for it. In fact, it makes me love them more. What else is there to do in this life, and how am I any different from the rest? That is what I think as I gulp down the nearest bowl of water, laced with the smell of mint leaves and bitter almonds. Do not pity me. I am the better for it. Like Mithridates, such lifelong habits as these protect me from poisons and keep me safe from the culinary designs of my enemies, even those who do not think themselves my enemies, my friends. It is not their fault I feel this way. It is no one's fault I find myself im-

prisoned on this island, this rocky hill with its little house, its beaches of pebbles and sand, bound on the one side by water and on the other by grasses and reeds. Worse things than this have happened. I hear about them all the time. I am blessed and know it and, except in times of depression, anxiety, histrionics and fear, grateful for my home, my surroundings and my lot in life. A fly is buzzing in my ear. I take it as an omen. A fly means worms are nearby. Worms are always nearby, waiting patiently. They are little bodhisattvas, giving themselves again and again, unconsciously and selflessly, to the greater good. Guileless, filled with irony, their machinations crank the wheel of life endlessly in a single forward direction, like a clock or corkscrew. As comfortable on a pile of shit or inside a dead animal as under emerald leaves, bright, blossoming flowers and pastel butterflies, they clock in and clock out, dutifully observing the company rules, never complaining. They are functionalists, through and through. They have no interest in structural economics, conflict theory or religious studies. There is something in my hand. Perhaps I have caught a fly. It is a piece of paper. Not the same piece of paper as before. It has something written on it that I cannot quite make out, since I cannot see in the dark. I ask the person next to me to read it for me. They whisper in my ear, I love you. What was that? Could you repeat that? I said, I love you. I am speechless. Someone loves me. I need time to think. For one, I am alone. Perhaps not. For another, whose hand is that in my lap? Is it mine? I cannot tell. Is it the hand of the one who loves me, or someone else? Is there a third party involved already? Am I engaged in a ménage à trois, or is a jealous outsider trying to come between me and my new love? Shouldn't there be some lips around here somewhere? I have nothing but questions. Smells of frankincense and sandalwood fill the room. Pheromones no doubt. I hear poets chanting in a dozen languages. I cannot concentrate. I can barely concatenate. You would think that I had learned my lesson, that I would know better than to try and write it down. Like a person with a severe memory or monetary disorder, I repeatedly scribble down all the things I think I know, hoping to use the words at some later time as currency, to exchange them for the memory of other things, things that I have seen and done for instance, or think I have, or wish I had, hoping not to have left anything out. You always leave something out.

III

Society of Words

The world is what is said.
Sed. Ded. Red. Sed.
You sed that already.

In order of appearance: signal/sensation, noumena, gesture, metaphor, icon, number, picture, words, statements, . . . think about it, . . . just kidding.

Where language is concerned, the universe is a collection of objects and events from which can be constructed gods, governments, philosophies and many other shiny things.

Each word a hyperlink . . . each letter, each neural impulse, each not-a-word.

I used to say plethora a lot, but then I saw a movie with a plethora of plethoras in it, so I don't say it much anymore.

A single word can split the universe in two: Cannot. Can too.

Language is not a narrative, but a strategy. Language allows causal chains to extend from the past into the future. Actually, I guess it is a narrative.

Ultimate dirty word: FUCUSHPITIMOCOKCNTISTSTSTHCKERSUCUCKEKERR
(Usually abbreviated Fucushpitimoco and pronounced foo-coo-ship-it-em-o-co)

Life is a hallucination. Everyone is constantly hallucinating. Hallucinations lie near the root of consciousness and are the same quantum neural events that lead to recognition, thoughts and dreams. It is only on certain occasions that our deeper hallucinations come into the foreground and we experience the moment as a type of enlightenment (or alien abduction, paranoid delusion, apocalyptic revelation, etc.). As long as our hallucinations maintain a close correspondence with the hallucinations of others, the physical world remains relatively stable.

I can understand the religious desire to question natural science: evolution, cosmology, statistics and so forth. But you really shouldn't argue with gravity. Gravity is our friend.

My favorite proper nouns are She, He, IT, . . . Oh wait, . . . those are my favorite pronouns.

Thinka Tanka

a read write head a strip of paper a set of rules for reading and writing symbols
language a turing machine an author

There were ten (now changed to eleven) dimensions before the Hot Big Bang. They split into twin universes, one of them four dimensions in size and the other one six dimensions in size. (We live in one that has four dimensions.) Our <conjoined?> twin universe is curled up so tightly you can only see it through a math microscope. Since I'm not a theoretical physicist I have no idea what is actually going on down there. I have to trust popular science books, documentaries and TV specials. And another thing. Ten dimensions lets you add gravity to the other three forces in the universe: electromagnetism, the weak nuclear force (i.e., radiation) and the strong nuclear force (the glue in the nucleus), which is a good thing. Unification is almost always a good thing where science is concerned. But ten dimensions still aren't enough to get the job done. The reason ten dimensions aren't enough is because there are at least five different ten dimensional models. The purpose of an eleven dimensional model is to make the various ten dimensional models get along with each other instead of fighting over who gets top billing. The guy who came up with the eleven dimensional model gets top billing. It helps to think of the eleventh dimension as a type of secret decoder ring that allows you to move back and forth between the various ten dimensional models. Since the whole thing is not testable, it doesn't hurt anything if you want to have an entirely different theory. There was never anything magical about ten dimensions. There isn't anything magical about eleven dimensions. The reason there were ten dimensions in the first place is because you need ten dimensions to hold the observed and theoretical data associated with contemporary physics. Nine dimensions doesn't give you a big enough container. Eleven dimensions is overkill. And even with all of this, there's still no graviton (i.e., gravity particle) in sight. We're still short a graviton. There may not even be a graviton. What to do? What do to?

We could not yet write, we had no art in us, but we would reach from branch to branch drawing our finger down the length of each mimosa leaf, watching them fold together. Later, in the woods there was a great stone tree trunk lying above the ground, petrified yellow, pink, orange, ochre and purple. We climbed on it and pushed each other off, yelling and laughing, I am king. No, I am. And again, walking around the corner, holding my Mother's hand I saw a black man up to his shoulders in a hole, digging, with three white men standing above, looking down. Don't stare at them, my Mother whispered, or they might be mean to him once we are gone. The blind casts slats of pure, white light across the room -- the floor, the chairs, the wall. It casts the shadows in between the light. Motes drift from one space to the next, appearing and disappearing, uncounted. Honey-suckle, blackberry vines and poison ivy line the fences in the alleyways. Nine years old, selling Grit papers door to door I find a dog by the road, lying with its tongue out, bleeding from the mouth. I knock on the nearest door. There's a dog hurt out here. Two boys come outside and stand beside me. Is that your dog? I ask. Yes. The smaller one is crying. The bigger one tells him, Go get my gun, then turns to me. Thanks. Now get out of here. And don't turn around to look.

Overheard near the constellation Canis Majoris, "You're so Sirius. Why do you always have to be so Sirius?"

What is The Big Idea, anyway? The Big Idea leads inevitably to the Society of Words, a secret society so secret it may not even exist. The purpose of the Society is to guide the social and scientific evolution of mankind.

Posthumous William Carlos Williams poem: The wheelbarrow is red. The chickens are red, too. Every damn thing in the place is red.

There *are* twin universes. One of silence. One of language. Silence leads to silence. Language leads to everything else with the possible exception of sight gags.

That's what makes cosmology so great. That's why philosophy can never go out of style. Because physics, mathematics and language collectively describe the last great metanarrative: a metanarrative not made of politics, or economics, or

psychology, or religion or history, but of pure reason.

So who was born in Thuringia, you ask?
Saint Elizabeth (of Thuringia),
Meister Eckhart,
Thomas Munzer,
Martin Luther and
Karl Marx for starters.
Yeah. That's right. Thuringia.

On an interstellar travel brochure for Earth: "If you're looking for apocalypse and utopia in that order, you've come to the right place."

If you doubt, if you're skeptical, that's a good thing. It means you're thinking your own thoughts and reading your own moral compass or astrolabe or GPS or whatever. It means you're a glutton for punishment because you think thinking makes a difference, that the bicameral mind is like a long term sexual relationship -- you can feel the other person even when they're not there. As a result, it means you're less likely to torture, rape or kill the innocent without thinking about it first. It also means you'll be one of the first people to go once your government does. Unless you live in San Francisco or New Orleans.

I used to read detective stories. Then I started whispering the ends of movies into my friends' ears in the middle of the movies, even though we were all watching them for the first time. I was mostly right. My friends eventually stopped asking me to go to the movies with them. That's when I stopped reading detective stories.

He changed the title of his first and only novel (unpublished) from *Sixty-eight Years of Solcitude* to *Sixty-nine Years of Solcitude*.

There is much beauty in silence as in noise. As beautiful as sound is. Music. Barks. Whispers. Words. Instruments of nature. Chirps, wing rustles and bill rat-

bles of birds. Water in all forms. Wind. Anything that moves. More and more, years pass and nothing is taken for granted. Not the job, the insurance, the house, the car, the children's education, retirement. A euphony of events, a landscape, a grammar for the ends of days. Death is only silence to the dead. It is a roar in the ears of the living in that moment when it comes. The false silence that follows is as burst eardrums, a fortress gate slammed shut, groaning against the battering and fire.

Answer the following:

In one-hundred years I would like to be:

Alive

Dead

Re-born

Immortal

Other

In one hundred years I would like to look like:

I do now

A digital photograph

A mythological being

A sphere of pure energy

I don't know

In one thousand years I think the world will:

Be destroyed

Be just like the movie Zardoz

Be utopia

Be pretty much like it is now

Be a lot hotter than it is now

If I could live at any time in the past one-thousand years or the next one-thousand years I would:

Kill myself

Be Elizabeth I

Be of another species

Live in a time and place the opposite of this one

Be here now

Rank these words in order of importance:

Thought

Emotion

Sensation

Boredom

Boredom

In one-thousand years, thought will be comprised of:

Bioelectrical impulses

Language

Advertisements

Anti-thought

A secret is:

A lie waiting to be told

A truth waiting to be told

Both

Neither

Either

I'll never tell

Describe yourself in ten words or less.

For example: Sometimes I feel like I am going inane.

Which of the following best describes your sexual orientation:

He pushes her backwards on the bed and as he wiggles his finger into her, laughs and says, Don't fight it. You know you like it.

She pushes him backwards on the bed and as she wiggles her finger into him, laughs and says, Don't fight it. You know you like it.

She pushes her backwards on the bed and as she wiggles her finger into her, laughs and says, Don't fight it. You know you like it.

He pushes him backwards on the bed and as he wiggles his finger into him, laughs and says. Don't fight it. You know you like it.

All of the above.

Most of the above.

Some of the above.
None of the above.

If sex is so bad, where did all these people come from?

What if you could get your hands on a big Internet search engine and analyze, in real time, the relative frequency of words in all languages and the relative frequency of certain combinations of those words and then use that information to capture changes in the collective consciousness, specifically as it relates to the investor psychology of well-defined markets and then use *that* information to predict and capitalize on short-term changes in share prices? Would that be a good thing or a bad thing?

Why is it I have never seen, "It's decidedly delicious!" trademarked on any food product?

Life can hurt sometimes, especially when you don't get your way or when you do and later wish you hadn't and also when you first pop your head out into the world (that really hurts) and again just before you die.

Opinion is one thing. Fact is the other. Television news is a joke.

Human beings can best be recognized by the empathy they have for others, regardless of ethnicity, or social or physical distance, or even shoe styles. Especially shoe styles.

I can't Desiderius if I like Erasmus or not. Isn't he the one who said, "life has no sweetness without a hand to live with?"

The origin of human language lies in the physical orientation of the primary sensory organs to external stimuli, particularly in the presence of other humans. Stimulus response patterns: glossolalia, propheteialalia, literals, variables, classes, attributes, relations, tropes, generative grammars and heteroglossia are

all ultimately manifestations of the interaction of the messages exchanged among external sensory receptors and internal sensory receptors.

Two thought police are sitting side by side observing a suspect. One says to the other, What do you think he's thinking? The other one replies, What do *you* think I think he's thinking?

Reader, beware! No, . . . actually, that isn't what I wanted to say. I'm not sure what I wanted to say, but that wasn't it. No. Not really.

We're leaving the apartment and her grandmother says, Did you leave the gas turned on in the kitchen? We never use the oven, we microwave everything, but before I can stop her my girlfriend runs back inside to check. This all happened years ago.

About to have their picture taken, eighteen words jostling to see who gets to stand next to who.

Abouttohavetheirpicturetaken,eightsixcharactersjostlingtoseewhogetstostandnexttowho.

Of course the messages that course through our brains are quantum in nature. Otherwise, the garden hose would have nothing else to do but lie around the house all day. How else could we travel in time or be in two places at once?

Oozing testacles. Oozing and oozing. Like a meringue that didn't quite make it, droplets string out like sticky rain upon a window pane, slowly gathering into bigger drops. Eventually they snake their way to a linoleum floor where they disappear into a constellation of stains. That is their destiny . . . Did I say testacles? I meant tentacles.

It sometimes becomes necessary to stick something between the thing in front of or on top of a thing and the thing behind or underneath it. Sandwich lovers know this all too well.

O

I i

I i

I i

I apologize for every cruel thing I ever said about Concrete, Oulipo and L-A-N-G-U-A-G-E P-P-P-P-P-P-PPP-Poetry\\

You start off thinking you're the god of MARS and end up standing there with your head up URANUS.

Carved in stone the stele read, Whether in war or peace, technology will kick your ass every time.

Even so, I can still picture a world at peace, a world with clean air and water, a world in which each person lives a life free of fear and filled with opportunity and hope. I'm not kidding.

MEAN MAN

I'll sue you. I mean it.

I'm sorry it happened and it won't happen again.
What? You're sorry you did it and you won't do it again.
No. I'm sorry I got caught, and that won't happen again.

Newspeak math question: How much is one doubleplusungood plus one plus-good minus one undoubleplusungood?

What kind of success is it when your go into a service station bathroom and find your poetry written on the wall?

"That which does not kill us," is not a very reassuring way to start an aphorism.

Which is more?

{{{{{ { ... or
{{}}{}}{}}{}} . . . } or
{}}{}}{}}{}}{}}{}} . . . or
... ((...{{}} ... {{}}{}} ...

I was wiggling the baby's toes and counting piggies: This little piggy went to market; this little piggy stayed home; this little piggy went with the first little piggy and this little piggy is trying to understand how doing it this way is any better for the baby than doing it the way everyone else has done it for thousands of years.

If I could look in every direction at once, I can't imagine what my face would look like.

When I was young, my one desire was to achieve perfection in all things spiritual. But for humility, I would have succeeded.

Solitude is the peace of knowing no one is going to bother you for awhile.

On the one hand, you would like to have some association with the truth. On the other hand, there are infinitely many categories in the world of which you are not even a random sample.

Who in this world would be willing to start over from nothing? To begin as nothing: selfless, without ego or identity, spontaneous, subjective in all things? That's what I thought. Ok, what if you only had to say you would be willing to do it, but you didn't actually have to do it?

Enlightenment: 1. [n] The perfection that transcends the cycle of reincarnation.
2. [n] An apartment complex for enlightened people.

Writing as a form of philosophy, especially when applied to poetry, has less to do with writing than with thinking, with speech than with writing. It represents an aesthetic that engages the conscious and unconscious mind in the creation of artifacts that have the capacity to both record and elicit the most complex states of mind and being of which we are capable. So does everything else.

When you read these words, try not to think of any other word but these.

Bending down, s/he picked up a small, injured bird from the ground. Holding it closer he found it to be uninjured and a bat. She set it down and it soon bounded away with its tail wagging between its st/ars/e, I mean its e/ars/e. “W/oof w/oof” “B/arf b/arf” “W/oof b/arf” “B/oof W/arf w/oof”

A man of Seville is shaved by the Barber of Seville if and only if the man does not shave himself. What sex is the Barber?

I reach down to touch my toes. On the way I pass my belly button and pause to meditate.

Where tragedy is concerned, why isn't satire ever the first thing you do instead of the last thing you do? Besides making you laugh, what good is it if the joke always comes after the fact?

poem without

punctuation

or capitalization

i am writing this

i am not words

these words i am writing

are not the words

i am thinking

i am writing

or if not writing

at least thinking

iamb

When you say a thing like, "Love is the parent of gravity," you shouldn't assume that the love part of the statement is any less literal than the gravity part. We have yet to discover the graviton, a theoretical sub-atomic particle having no mass and no energy, responsible for the gravitational force. Love, on the other hand, remains as good a description as any of the singularity out of which gravity was born. Gravity, the parent of life, is also the means by which life creates its own environment, its own atmosphere. As an effect of gravity, love becomes a living thing.

The problem with happiness is its tendency to stay that way unless somebody does something to fix it.

Eight logical phallacies:

Ad Hominem

Bill said you drank my vodka.
How can you believe anything Bill says? He's got a little dick.
You don't say?

Ad Hominem Tu Quoque

Unsafe sex is dangerous.
Is that so? Did you use a condom the last time *you* had sex?
I'm a woman. Besides, I had sex with you.
Well then, I guess it can't be *that* dangerous.

Circumstantial Ad Hominem

Fellatio is a leading cause of strangulation.
If you don't want to do it, just say so.

Burden of Proof

You slept with my best friend.
Prove it.
If you're going to talk like that, what else are you hiding?

Red Herring

You slept with my best friend.
Prove it.
Look at these pictures.
What were these things made with anyway, Photoshop?

Begging the Question

Why should I go out with you?
Because I'm a great date. Ask my friend Bill here.
Why should I believe Bill?
I told you. He's my best friend.

Questionable Cause

Science has proven that women have a stronger evolutionary link with fish than men do.
<Silence.>
It's the smell. The same chemical in a woman's vaginal fluid, trimethylamine, that makes her smell like a fish makes the fish smell like a fish.
So let's see. What does that say about men, seawater and Clorox, or as you might put it, sodium chloride and sodium and calcium hypochlorites?
Huh?

Exclusive Premises

I'm smart, good looking and rich. Lots of women sleep with me. Give me one good reason why you won't sleep with me.
I don't have to have a reason. Besides, you forgot to mention you're a jerk.

For thousands of years we had the sun, the moon, the stars and planets . . .
Now we have the Hot Big Bang, dark matter, supernovas, black holes and the multiverse.
For hundreds of years we had the Hot Big Bang, dark matter, supernovas, black holes and the multiverse.
Now we have . . .

One, two, three, four, five, six, seven, eight, nine, ten, . . .
One, two, three, five, eight, thirteen, twenty-one, thirty-four, . . .
Two, three, five, seven, eleven, thirteen, seventeen, nineteen, . . .
Twenty-four, thirty-seven, forty-eight, fifty-one, hike, . . .

The worst parts of history are when people do terrible, stupid things and the world unexpectedly and unfairly turns out ok in spite of it. Or are those the best parts?

All empires, without exception, have been built on slavery. That is not at question. The real question, especially in a democracy, is, where can you find a lot of volunteer slaves?

Stolen (old) Russian joke:

The man comes to work with his clothes all rumpled. His co-workers ask him what is wrong. He says, I turned on the television this morning and there was the President telling me that a vote for him was a vote for god. I changed the channel and there was the President again, telling me that a vote for him was a vote for god. I changed the channel again and there he was again, telling me that a vote for him was a vote for god. So I turned off the TV and turned on the radio and there he was again, telling me that a vote for him was a vote for god. I was afraid to turn on the iron.

Lying is easy. Just try it, "Lying is easy."

The iconoclast begins his day by deliberately saying and doing exactly the same things as all the other lumberjacks in the building, all the while thinking to himself, No one knows the present, much less the future.

How do you get from symbol to metaphor? How do you describe nature and the social order in terms of symbolic logic: classes, attributes, relations, propositional and predicate grammars? How do you come to a final understanding of language, reason and natural law? You don't.

a.com (Reserved – Internet Assigned Numbers Authority)
aa.com (American Airlines)
aaa.com (American Automobile Association)
aaaa.com (American Association of Advertising Executives)
aaaaa.com (Domain Name for Sale) May, 2003

If you do not understand what I am saying, it would be a mistake to assume it is a necessary result either of what I am saying or of what you are thinking.

You cannot look at a poem and see the poet's inner life. Neither can the poet write a poem and see yours. Instead, you each find a way to be satisfied with the words.

Not the fictional "I" but I am writing this. Do you believe that?

After years of trying to complete his "Great American Tragedy" he finds himself staring at the sentence: How many chucks could a woodchuck chuck if a woodchuck could chuck wood?

The production of consciousness as a sentence.

You pick a thing
Any thing
And fix your attention on it.
It doesn't matter what it is.
It doesn't matter if it is in the world
As a physical presence or not.
An idea will do as well
As any physical thing.

In fact, the only thing that makes it
Matter at all is that you chose it.

And once you choose it
You look at it,
Think things about it,
Feel things about it,
Reach out to it
Because you know
And were born knowing
that touching it and holding it
Will make it matter more.

As love is the parent of gravity, so is desire.

I
want
your mind.
I want it
bad. The thought of your
mind makes me so hot I can't stand
it. C'mon. You know you want to . . .
Admit it. There is no end state to understanding.
Understanding is infinite in its reach.
God is not a static thing
and neither is truth, love, or any of the other
dominant modes, dialectics, tropes, etc.
that have served as the basis of our thinking,
speaking and writing
since we began thinking, speaking and writing.
It is not for us to say what God is,
whether or not God evolves,
or where God ends. God just is.
It's a little condescending to proceed as if God
is either nothing more than a great big period

at the end of a sentence  like a black hole,

or else non-existent or not even non-existent.

Regional Literature

The Southern poet jumped
through flaming hoops of fire,
rode bareback bareback,
and, for a grand finale,
stood head first on a high wire,
chickens roosting on his arms,
a bucket of eggs in either hand,
praying all the while, should he fall,
for the miracle of kudzu.

I dreamed I was a fashion designer. In my show, one line was of models painted in delicious sauces. Another line had the same models clothed in car parts.

In the fashion industry of evolution, who wants to be yesterday's species? Wouldn't it be better to go the dance dressed up as the next big thing in evolution? Wouldn't you rather be a cybernetic organism or an artificially intelligent online video game?

Isn't it amazing that the moment you think of yourself as being *you*, you suddenly begin to think of everybody else as being *somebody else*.

Plato said, "The gods do not seek wisdom, for they are wise already," but he never said how that applied to money.

Although he invented the steam engine, Hero never said, "Greed is like a gas. It expands to fill the available space." Even if he didn't say it or even think of it, given all those scribes and translators over the years, you would think someone before me would have stuck it in there somewhere.

Standing, sitting, lying or moving with another person in any number of social

postures one is likely to hear the question, What do you do? I was never inclined to give the name of an occupation as the one word by which I might be remembered. For a long time I gave my own personal pronoun in response plus the name of one or more verbs -- live, breath, eat, drink, sleep, etc. After my first divorce I would say, There are three sexes: male, female and human; I'm considering a sex change. Later, at dinner parties I would sometimes say, Although I do not understand it, I too am fascinated by it. Not the answer, but the question. Now I sometimes say, I don't know, but most of the time I say, Computers.

It's not funny.
It thinks it's funny.
It wants to be funny.
But it's not funny.

I cannot think of one society in which the weakest adult member is given the first right to food or life. As a species, we are not made that way. Somebody should become a geneticist and change that.

We desire unity.
We desire heterogeneity.
We desire to make a universe of words.
We desire unknown things for which there are words.
We desire known things for which there are no words.
We desire known things for which there are words.
We desire unknown things for which there are no words.
We desire luck in fate.
We desire fuck in late.
We desire justice without revenge.
We desire revenge without justice.
We desire not to desire.
We desire little or nothing.
We desire everything but nothing.
We desire a place to live, eat, sleep and do several other things.
We desire to start, stop and start anything we choose, again and again.
We desire to live without boredom.
We desire to understand the cause of suffering.
We desire to believe in meaning.
We desire to live effortlessly.
We desire to forget.
We desire to

We desire to
I forget . . . What do . . . What?

There is no greater gift in life than to enter it, is on my bumper sticker next to the one that says, Bumper Sticker.

Have faith and hope. Not in religion, science, government or money. Those are artifacts, fragments of a life. Leave them to the tumbrel. Have faith in yourself -- the universe as a unity. We have learned a few things recently. One, that life is quantum in nature. Two, that there is no end state to language or knowledge. Whether in a superdeterministic universe or a quantum multiverse, you are the things you see through the window of your morning and evening, your sleeping and waking. The great heresy is in the mirror, brushing its teeth. You are the great heresy. You and everyone you meet, all one and the same, all a unity. God is in you. God is what is left when there is nothing left but your breathing and the beating of your heart. God is what is left when your life leaves you, when your mind leaves you, along with everything you ever thought you were. God is in you and remains. Even if it is infinite in duration, this universe will grow cold, mindless and dark. In its own way, this universe will end. But God will not end. Not in this universe, or any other.

I've been buying two, sometimes three new books a week. They are some of the very best books money can buy. I'll soon have enough to finish my sculpture.

How much does it cost to buy a vote?
A little over \$20.
I can buy one down the street for only \$10.
You should go down the street and buy one then.
They don't have any to sell.
Are you a cop?

A few things that saying, "It puts food on the table" won't justify:

Genocide
Killing people for money
Buying and selling slaves

But wait! There's more!

Brokering women and children for sex

Torturing people

Letting people starve to death when you could feed them

Giving people drugs they don't need

Not performing necessary or helpful medical procedures

Not giving people drugs they need (see Genocide)

Cooking the books

Being cruel to animals

Extinction of your own and/or other species

Destruction of all life on earth

I've met a lot of wealthy people who are really good people and I've met a lot of poor people who are really good people, but I've also met some poor people who are really bad and I've met some wealthy people who are really bad. What I've learned is that if you are determined to categorize people it is best to work with a n-by-n matrix. .

It is impossible to love and to hate at the same time, unless you watch a lot of television.

I asked a Hollywood PR friend of mine what her worst nightmare was and she said, When a client shoves a gerbil up his butt and it gets stuck and you have to meet him at the hospital and convince the emergency room doctor that it's not really a gerbil.

In the second grade, Sister Catherine told me to put my hand down. Then she told the class she was giving prizes to the winners of the art contest. Then she told me to please put my hand down. Then she asked me to stand with a few other students in front of the class while she gave us our prizes. While I was standing there, she asked me to please put my hand down. That's when I peed all over myself. I saw it coming, too.

If there is one thing peaceful societies should have learned by now, it is never to let strangers near your stuff.

There is no such thing as a free press. Somebody has to pay for the advertising.

If you want to be a writer, write. If you want to be a painter, paint. If you want to be a politician, shame on you.

The next time you watch a hardcore porn movie, picture a cardboard box full of electrical plugs and wall sockets and no electricity.

You know you've made it when the establishment offers you a lot of money to just keep doing whatever it is you are doing, even if what you are doing is trying to destroy the establishment.

Everything of real importance has already been said by someone who had no idea what they were talking about.

Genius should never have to proclaim its own genius. It's embarrassing. There should be at least one other person around to proclaim it for you.

Each time I try to write a political poem, I almost always end up with the same first sentence: "You no good, lying, hypocritical, black-hearted, evil mother-fucker, who the hell do you think you are, stealing from the poor and working class just so you can funnel the loot to your corporate buddies, talking about your family values when the whole time you're either fucking around on your wife with someone else's wife or daughter or both, or gagging on some male prostitute's cock, or even worse, ramming it up some little boy's ass while snorting coke from between his shoulder blades, dosing yourself into oblivion with pain pills and alcohol and doing all the same things you accuse your political enemies of doing, just so you can say you're somebody, when in fact, you're nothing but a carpetbagging, lying, cheating, stealing, raping, murdering, worthless, sold-out sociopath who would steal the change out of a dying man's pockets, who would sell his own soul for money, who would take the lives of millions of innocent people, laughing and joking about it the whole time, because you think it's funny, that it's fun to kill people, to watch them suffer, laughing all the way to the bank, etc." That's why I don't write too many political poems. It's hard to get past the first sentence.

Political Poem

Communist totalitarianism
Socialist totalitarianism
Capitalist totalitarianism
Religious totalitarianism
International totalitarianism
Totalitarianism

I've tried to be a good American,
But I just can't bring myself
to want a lot of stuff.

One more thing:
Truth exists;
Love and Gravity exist.
You can be happy.

Where would the world be without imagination? Without my imagination, I don't know where I would be. My imagination has bailed me out of more messes than I can count.

Why is it that after only a few drinks, every producer, director and screenwriter at the party begins to refer to himself as a poet? They're almost as bad as the architects.

The greatest art is always made during that period when a high civilization has reached its peak and, through war or pestilence or moral failing, first begins its decline. If you are fortunate enough to be an artist living in such times, . . . sorry.

Nocturnal missions are when you dress up like special ops and do important, dangerous things in the dark. Nocturnal emissions are something else.

I had a dream. That was it.

IV

The Big Idea

We live in precarious times. Have no doubt of it. As Seneca the younger, whose plays and philosophy, noted for their selfless, tragic nobility and ranked among the greatest ever written, yet whose personal life was every bit as selfish, mercenary and mercurial as that of his pupil, Nero, would have it, *As many servants so many enemies*. Following a period of global expansion in which many people amassed enough wealth to last a thousand lifetimes; we are now in another period of expansion, in which many thousands more will also gain enormously, this time through the promotion and sale of fear. For each person so made, there are added thousands of poor who, sooner or later, will come to know, in all the detail the world can provide, the vast differences between their own lives and the lives of those their masters. Old and worn as this story is, it is made unique by the times; times prominently marked by the rapid evolution of the species; its population and genetic self-determination, its embrace of social hierarchy, its successful predilection for the technologies of communication, transportation, production and war, and its as yet unbounded reach in all things material. The fundamental equation in the matter, greed on the one side, fear on the other, is in itself the basis for a larger set of equations whose unordered outcomes seem to include the most unlikely results: peace, love, honor, prosperity, safety, respect, beauty, integrity, and all their kin. Such virtues and treasures, according to these reasoned measures, must find their origins in greed and fear; for if they do not, they represent something measured, not in self-interest, but in a thing that is, in its essence, an inequality, an asymmetry of the highest order. Perhaps this asymmetry is best understood as the relative strength of intentions on the parts of those who most believe in it, and those who choose not to believe in it at all, to believe against it. If, for some, this asymmetry is the result of hard effort, dedicated to the creation and preservation of wealth, in turn the source of safety, happiness and long life, the source of freedom itself, for what is freedom if not the desire and achievement of these; it is for others evidence of an imbalance in the relationship of one person to another, or one to many, or many to one, or many to many; it is an imbalance that puts all of nature out of kilter, into an unstable state, an anomaly, a risk of extinction to all. As likely explanations as these may be, there are, in addition, many other “for some” and “for others” serving a similar purpose; first ignored, then embraced and finally discarded by those no longer able to see themselves reflected in the mirrors of their own desires and pursuits. The sum of all this is the world as we see it, day in and day out, possessing in character the certainty that those events we experience directly are of as much consequence and weight as those we can only ever know through our trust or mistrust of others; combined with the knowledge of the possibility that we may fail completely in our efforts and never fully understand the true nature of anything at all. Bearing all this in mind, *these characters* have chosen to stand firmly in place as a testament to one thing only -- *The Big Idea*: the idea that all

ways of thinking about the world are in themselves part of something greater, something of such vast purpose that it knows itself from the very beginning to be both master *and* servant of all; that as representative as it may be of both our basest and most precious instincts, it remains in name an identity, no more, nor less, that must in its own turn find a place within the larger society of words. To this end, *these characters* are divided into two parts: those concerned with science and those concerned with art. To the ones concerned with art, let art be the highest form of mediation, whether between god and human or human and human or human and things, inanimate and living, our world included; and mediation as what we do in our every action, both within and outside ourselves, at every point and line and plane and space that Greed and Fear occupy; and likewise their children, Selflessness and Love, if indeed these are their children. To the ones concerned with science, let science be a search for equilibrium, not only as a way of keeping things in balance, for balance is more than a beam upon which the world maintains its footing in the universe; but as a way to understand the ever-changing landscape of our lives. If balance is found in gravity, so much the better, for gravity is a gentle attractor, and has within its purview all those things that are to be derived from it, and likewise all those things from which it is derived; whether they be love, or desire, or fear, or greed, or nothingness. But if balance is found elsewhere, let it be found in the service of art. As is the case with science, let art in its turn provide us with sight, hearing, taste and touch refined enough to see the truth behind our own and each others' eyes; able to measure that truth in the full light of day, with hope and reason. As with art, let science be a means by which we understand that times, places and motions have their own habits, their own language; an understanding not created by us, but shared with us according to the grace and wisdom of a higher purpose. Let art and science not be two, but one; the servant of many, the enemy of none.

Junk food is junk. Bad. Unless it's soy or tofu. I had a dog. And a cat, too. Protein folding is not easy work. It's a tree. A bicycle parachute is a tree. The root is "A." I like to watch TV. Me. Me. Me. Not only the differential, but also the partial differential. Yes. I am up but not down no not here not now no how. Yes. There is more. Always more. But never enough. Everyone careful on the stairwell. Big letters go first, followed by little letters, followed by dots. Mad Cow jumps backwards over five-hundred and forty characters. No telling how many interneurons. It's obviously not cereal in nature. Do you believe in interneurons? Do you believe in the Planck epoch? Mad Cow jumps in every direction. In time. This is thinking. This is reading. This is writing. This is/is not/ talking(?) What's orange and sounds like carrot? A dead orange parrot. What's the big idea? Forget that. Anybody? What's the right word? Two words. Three words. I like tea. Words. I have a car. I am not innocent. I know that s/he is not the right word.

Where is a word for s/he? A woman. Not a woman. Not a man/woman thinking a woman/man. How amazing it is to be. One hand up. Hello. Goodbye. One hand down. Two hands down. Three syllables. Empathy. Synecdoche. 1 2 3 4 5 6 6 1 5 2 4 3 3 6 4 1 2 5 5 3 2 6 1 4 4 5 1 3 6 2 2 4 6 5 3 1 (6 2) (1 4) (5 3) *sad and weary I go back to you, my cold father, my cold mad father, my cold mad feary father* sd ad waery I g bcak t yu my clod fthaer, my clod md ftaehr, my clod md freay ftaehr And another. And another. Stay calm. Hamburgers. Soup cans. Shoes. Flags. Targets. Plates. Empty chairs. Pipes. Coathangers. Basketballs. Don't anybody move. Fallacy. Fallac. Just one more tree. A forest of trees. How Romantic. Tree/s. See/s. Be/s.

Mikhail Tal
Bobby Fischer
1959
King's Indian Defense

1. d4 Nf6

Even with the best of intentions, habits are difficult to break.

2. c4 g6
3. Nc3 Bg7
4. e4 d6

Given the history of the book, what is the future of the book? This is the future of the book.

5. Be2 0-0

If only here, one's home is one's castle.

6. Nf3 e5
7. d5

Each time we transpose, we add to a world in which each thread of "conversation" lies near so many others that it becomes impossible to tell where the larger conversation begins or ends.

Nbd7
8. Bg5 h6
9. Bh4 a6

It can be frustrating, trying to keep track of every possibility. That is why it is important to think, not only with colors, numbers, letters and pictures, but with silence and emptiness as well.

10. 0-0 Qe8
11. Nd2 Nh7

Take an event with a beginning and an end, and a subsequent event, and create a third event with its beginning somewhere within the first event and its ending

somewhere within the second event.

12. b4 Bf6

Art. Logic. Balance.

13. Bxf6 Nhx6

14. Nb3 Qe7

Sometimes you are reaching and you know it, but you have always been this way. You may as well be trying to figure out how to drag a hippopotamus out of a marsh.

15. Qd2 Kh7

Avoid a style. A style does nothing more than denote a lack of imagination, relying instead on the comfort of doing one thing over and over. But to deliberately choose not to have a style is also slavish and dogmatic. If you choose to have a style, sharpen it to a fine edge and chisel your name with it in big letters.

16. Qe3 Ng8

17. c5

The simplest things can make or break us.

18. exf5 gxf5
19. f4 exf4
20. Qxf4 dxc5

Why do we do the things we do?

21. Bd3 exb4

22. Rae1 Qf6

23. Re6

Allow yourself to move intuitively and it will surprise you. It will soon show itself in every detail. Perhaps in the next move. Or the one after that. But you have to do it when you know it's there. Otherwise, you'll always be one move too late. Don't be afraid to sacrifice everything once you are certain.

24. Qxc3
Bxf5+ Rxf5
25. Qxf5+ Kh8

If you're thinking about fortune cookies or horoscopes, bumper stickers or new age audio CDs, it's ok. It's all part of life's rich tapestry.

26. Rf3 Qb2
27. Re8 Ndf6
28. Qxf6+ Qxf6
29. Rxf6 Kg7
30. Rff8

Symmetry and asymmetry are everywhere, subtle in their convergence and divergence.

31. Na5 Ne7
 h5
32. h4 Rb8

Why shouldn't they be?

33. Nc4 b5
34. Ne5 Resigns

The Relationship of Entropy to Message Size in Binary Symbol Strings

1.0 Introduction.

Early in the twentieth century, quantum physics demonstrated that the universe is random in its essential nature. More recently, Gregory Chaitin has shown that any set of symbols, such as the set of positive integers, can be used as input to generate an infinite set of random binary digits or bits. His conclusion is that there is infinitely more randomness than order in the universe. However, the opposite is also true. *With only a few exceptions, any string of bits, random or otherwise, can be shown to have an information content that will always be expressible using fewer bits than the original string.* This is another way of saying that, at the very least, order is coequal with randomness in its authority and effect.

In information theory, a string of symbols transmitted from one place to another is commonly referred to as a message. Entropy is a term used to represent the information content of a message. The calculation of entropy for a given message (i.e. string of symbols) represents the actual information content of that message as measured in bits. If the calculation of entropy for a given message results in a number value that is less than the number value (as measured in bits) of the original message, the message is considered to be compressible. Compressibility is a measure of randomness in a message. A purely random binary symbol string is considered uncompressible. As a corollary, a purely random binary symbol string should have entropy equal to the number of bits in the symbol string. If the entropy for a binary symbol string is less than the number of bits in the symbol string, the symbol string is not considered random.

When entropy is calculated by viewing a message as a collection of binary symbols with each symbol being one bit in length, the following assertions prove the entropy for any string of bits or symbols to be less than the number of bits in the string for all strings 5 bits or greater in length. Given an infinite number of possible messages, the only exceptions to these assertions are the binary symbol strings 01, 10, 0011, 0101, 0110, 1010, 1001 and 1100. This means that almost all messages, random binary data included, can be shown to have an information content less than the number of bits in the original string or message.

2.0 Definitions.

Entropy is defined as the minimum number of binary digits necessary to encode

a message.

A message is defined as a string S of symbols.
Each symbol in S is a member or element of a set T .

The number of elements in T , also referred to as the base, is designated $|T|$ and is equal to the number of unique symbols occurring in S .

The entropy for a given symbol s in S is calculated as:

$$- \log |T| (s_n/S_m)$$

where

s_n equals the number of occurrences of s in S and
 S_m equals the total number of symbols in S

The entropy for a collection of like symbols s in S is calculated as:

$$- \log |T| (s_n/S_m)(s_n)$$

The entropy for S is calculated as the sum of the entropies for all collections of like symbols in S .

3.0 Assertions and Proofs.

The following assertions and proofs demonstrate the relationship between entropy and message size in binary symbols strings as being one in which the entropy is less than the number of binary symbols in the symbol string. In all cases, a binary symbol takes the form of and is equivalent to a binary digit.

3.1 Assertion A.

For any string of binary symbols of odd length greater than or equal to 3 that contains at least one of each type of binary symbol, the sum of the entropies of the two types of binary symbols in the string is less than the total number of binary symbols in the string.

3.2 Proof of Assertion A.

Given a string S of n binary symbols,

Where:

- (1) n is both odd and an integer greater than or equal to 3,
- (2) each instance of a binary symbol is equivalent to a binary digit or bit and
- (3) both types of symbols are represented in the string,

It follows that

- (4) the string S is divisible into two sets of binary symbols of like type and
- (5) one of the two sets of binary symbols will always contain at least one (1) more member than the remaining set of symbols.

Therefore, given (v), calculating the entropy for each set of binary symbols and adding the resulting values will always result in a number less than the total number of binary symbols in the string.

For example:

Where n = 3 the possible combinations of three bit symbol strings are:

000, 001, 010, 011, 100, 101, 110, 111

With the exception of 000 and 111 (whose members are of like type and the calculation of whose entropy, because it requires division by 0, is undefined), the calculation of entropy for the remaining combinations of binary symbols results in the following values:

A sample calculation for symbol string 001 is:

$$(-\log((2/3), \text{base } 2)*2) + (-\log((1/3), \text{base } 2)*1) = 2.754888$$

In all cases the number of binary digits in the original message (3) is greater than the sum of the calculated entropies for the collections of like symbols contained in the original message (2.754888).

In summary,

Where:

$$n = (1, 2, 3, \dots),$$

A = Assertion A and

$$N = 2(n) + 1,$$

It follows that

A(3) is true and therefore A(N) is true.

Note A: In all cases in which a binary symbol string contains only one type of symbol, the calculation of entropy, because it results in division by 0, is undefined. One solution is to add a single symbol of a second type to the string. Entropy can then be calculated using $|T|$ equal to 2, or base 2. For example, the binary string 000 can be converted to 0001. Using this method, all symbol strings of like type with a length of 4 or greater will have entropy less than the total number of symbols in the string. For example, the binary string 1111, after placing a symbol of a different type anywhere in the string (e.g. 01111), will have entropy of 3.60964.

3.3. Assertion B.

For any string of binary symbols of length n , where n is both even and a whole number greater than or equal to 6, by dividing the string into two substrings of odd length and applying Assertion A, the sum of the entropy of the symbols can be shown to be less than the total number of symbols.

3.4 Proof of Assertion B.

Given a string of binary symbols of length n , where n is both even and a whole number greater than or equal to 6,

It follows that

- (6) since the string is divisible into two substrings, one substring of length 3 and the remaining substring of length $n - 3$ and
- (7) since the sum of two odd numbers is always even and the sum of an odd and even number is always odd, the remaining substring must be an odd number of binary symbols in length.

Therefore, given Assertion A, calculating the entropy for each substring and adding the resulting values will always result in a number less than the total number of binary symbols in the original string.

In summary,

Where:

$$n = (3, 4, 5, \dots),$$

A = Assertion A,

B = Assertion B and

$$N = 2(n),$$

It follows that

A is true and B(6) is true and therefore B(N) is true.

3.5. Assertion C.

For any string of binary symbols of infinite length, such as those representing irrational numbers, by dividing the string into two substrings, the first of which is of odd length greater than or equal to 5 containing at least one of each type of binary symbol (see Note A), and the second of which is the remaining symbols in the string, by applying Assertion A, the sum of the entropy of the symbols can be shown to be less than the total number of symbols in the string.

3.6 Proof of Assertion C.

Given a string of binary symbols of infinite length,

It follows that,

- (8) the string is divisible into two substrings, one substring of odd length 5 or greater (see Note A) and the remaining substring of infinite length.

Therefore, given Assertion A, by first calculating the entropy for the first substring and then successively adding the value of each succeeding binary digit (i. e., 1) in the second substring to the sum, the total will always result in a number less than the total number of binary symbols in the original string.

In summary, where:

$$n = (2, 3, 4, \dots),$$

A = Assertion A,

$N = 2(n) + 1$

It follows that

A is true, A(N) is true and therefore C is true.

The Relationship of Sample Space to Sample Size in the Calculation of Entropy for Random Binary Symbol Strings

1.0 Introduction

The relationship of sample space to sample size for random binary data can be shown in every case to take the form of a curve in which the percentage difference between the calculated entropy and the sample size decreases as the sample size increases. *What this means is that for any binary symbol string, even quantum random binary data, the data can be organized in a number of ways, each of which results in a calculation of entropy (as measured in bits) that is less than the number of bits in the original string.* This applies to all random binary symbol strings, whether they are of finite or infinite length.

By sample space is meant the total number of possible events or outcomes for a given set or collection of events. For example, the possible outcomes when rolling a die are {1, 2, 3, 4, 5, 6} or 6. The possible outcomes for a binary digit are {0, 1} or 2. The possible outcomes for a binary word of two bits in length are {00, 01, 10, 11} or 4. By sample size is meant the actual number of events that are measured. Three rolls of a die have a sample size of 3. Five flips of a coin have a sample size of 5.

2.0 Example

As an example, the following model describes a string of random binary digits or bits as a series of five (5) 1-bit words. For any string of random binary data used as input to the model, the percent difference between the size in bits of the original data and the resulting entropy is approximately 12.2%, that is, the calculated entropy in bits is roughly 12% smaller than the actual number of bits in the sample space.

Example:

Given a string S of random binary digits 5 bits or greater in length,

where:

- (9) the string S is divisible into one or more substrings (i.e., $S_1, S_2, S_3, \dots, S_n$) each with a length of 5 bits and a single remaining substring with a length of 0 through 4 bits and
- (10) each substring of 5 bits is divisible in turn into two sets of binary symbols of like type (i.e., 1s and 0s),

the entropy calculations for each possible set of 5-bit substrings and their sum is con-

tained in the following table:

Substring	Entropy	Substring	Entropy	
00000(1)	3.60964	10000	3.60964	
00001	3.60964	10001	4.854753	160 Total Bits
00010	3.60964	10010	4.854753	140.41 Total Entropy
00011	4.854753	10011	4.854753	12.24% Percent Difference
00100	3.60964	10100	4.854753	
00101	4.854753	10101	4.854753	
00110	4.854753	10110	4.854753	
00111	4.854753	10111	3.60964	
01000	3.60964	11000	4.854753	
01001	4.854753	11001	4.854753	
01010	4.854753	11010	4.854753	
01011	4.854753	11011	3.60964	
01100	4.854753	11100	4.854753	
01101	4.854753	11101	3.60964	
01110	4.854753	11110	3.60964	
01111	3.60964	11111(0)	3.60964	

Those substrings with values of 00000 and 11111 (whose members are of like type and the calculation of whose entropy, because it requires division by 0, is undefined), can be included in the calculations either through a) the change of a single symbol to one of unlike type within the string or b) the addition of a single symbol of unlike type to the string. In the first case, the substring “00000” once converted to “00001” will result in an entropy of 3.60964. Likewise, “11111” once converted to “11110” will result in an entropy of 3.60964. In the second case, the substring “00000” once converted to “000001” will result in an entropy of 3.900135 and “11111” once converted to “111110” will result in an entropy of 3.900135.

In a random collection of symbols, the frequency of each symbol is roughly equivalent to that of every other symbol. This equivalence increases with sample size. Therefore, by assuming a fully random distribution of these substrings within a larger random binary string and by calculating the entropy for each substring independently of the others and summing the results, the total entropy for the larger random binary string can be calculated. In the above example, for any large random binary string, the entropy will always be in the range of approxi-

mately 87.76% of the size of the original (source) string for a difference of 12.24%.

Furthermore, the percent difference between the size of the original string of random binary digits and the calculated entropy varies with sample size. The following graph shows the percent difference between the calculated entropy for a series of 1-bit words with different sample sizes. In this instance the percentage difference increases from approximately 8% for a 3-bit sample space (i.e., a random string of bits divided into groups of 3 1-bit words with each group having 2^3 or 8 possible combinations) to 12.24% for a 5-bit sample space (i.e., a random string of bits divided into groups of 5 1-bit words with each group having 2^5 or 32 possible combinations) after which it gradually decreases as the sample space increases.

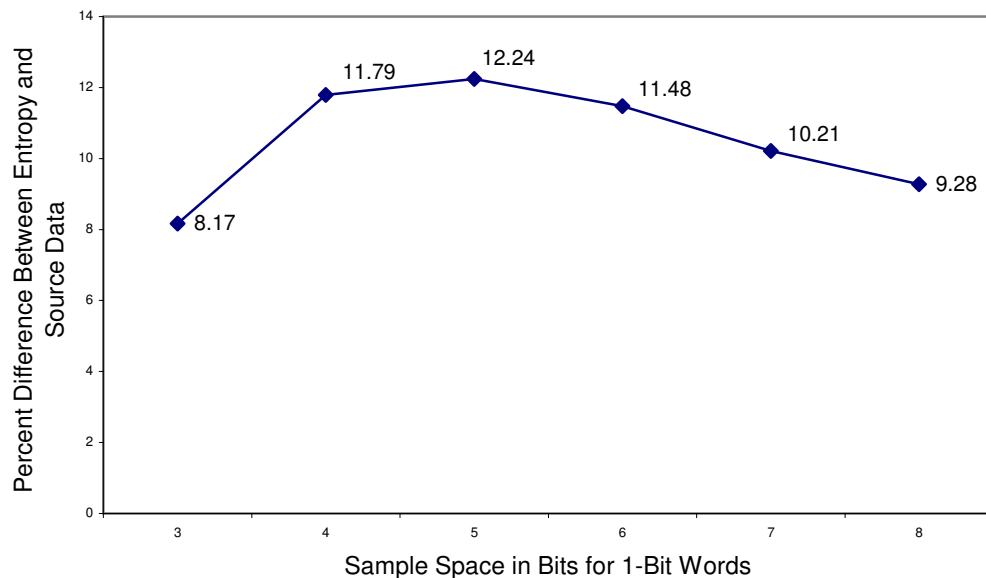

3.0 Varying Sample Space and Sample Size

The calculated entropy for a random binary string varies with sample size as well as with sample space. In all cases, the same number of total bits will have different values of entropy based on sample space and sample size. What this means is that any change in the number of bits per word will change the entropy and any change in the number of words in a block (i.e., the sample size) will change the entropy. For example, the total possible combinations of binary symbol strings 6

bits in length represent a sample space of 2^6 or 64. Multiplying 64 by 6 (bits) results in a total of 384 bits. Each 6-bit binary symbol string can in turn be organized into 6 1-bit words, 3 2-bit words and 2 3-bit words. Even though the total number of (random) bits is the same for all three models, the percent difference between the entropy and the actual number of bits for each model is 11.48%, 41.58% and 66.67% respectively. The following graph shows the percent difference between the calculated entropy for a series of 2-bit words with different sample sizes.

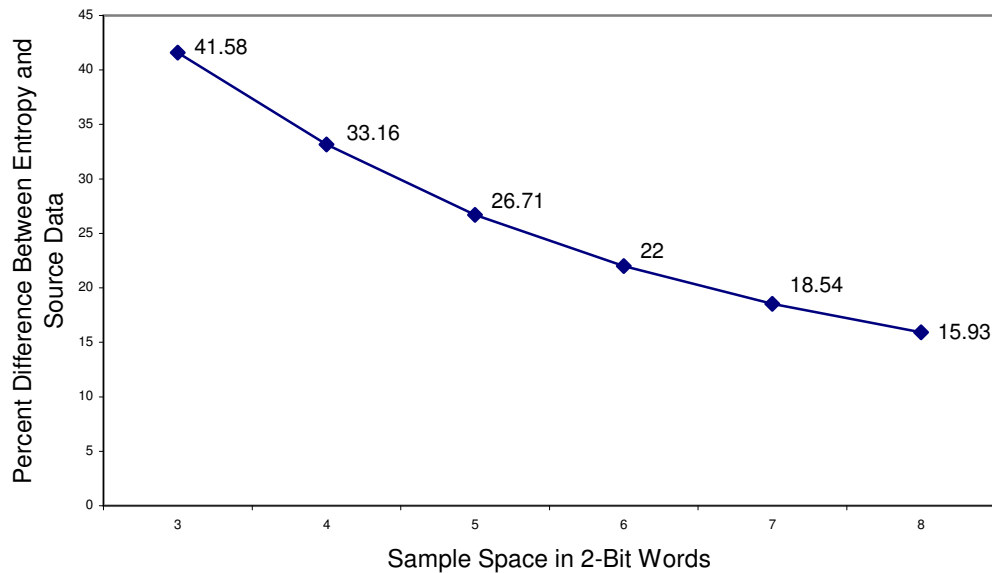

In the above graph, the same data is subdivided into groups of 3, 4, 5, 6, 7 and 8 2-bit words. When calculated as a series of 3 2-bit words, the percent difference between the actual number of bits in the source data and the calculated entropy is 41.58%. When calculated as a series of 4 2-bit words, the same data results in a percent difference of 33.16%. The percent difference between the actual number of bits and the calculated entropy decreases as the number of words used in the calculation increases.

By changing the sample size (i.e, the number of binary words used in the calculation of entropy) and the sample space (i.e, the total possible combinations of bits based on the number of bits in a word), it is possible to vary the calculation of entropy and maximize the percent difference between the number of bits in the data and the calculated entropy for that data. The following table shows the total bits, calculated entropy and percent difference for various combinations of 1, 2, 3 and 4-bit words.

Word Length in Bits	Block Length in Bits	Words per Block	Total Bits	Entropy	Percent Difference
1	3	3	24	22.03	8.17
1	4	4	64	56.45	11.79
1	5	5	160	140.41	12.24
1	6	6	384 (1)	339.89	11.48
1	7	7	896	804.49	10.21
1	8	8	2048 (2)	1857.75	9.28
2	6	3	384 (1)	224.31	41.58
2	8	4	2048 (2)	1368.74	33.16
2	10	5	10240	7504.51	26.71
2	12	6	49152 (3)	38335.14	22
2	14	7	229376	186843.74	18.54
2	16	8	1048576	881495	15.93
3	6	2	384 (1)	128	66.67
3	9	3	4096	2082.5	54.8
3	12	4	49152 (3)	26960.86	45.14
3	15	5	491520	304601.54	38.02
4	8	2	2048 (2)	512	75
4	12	3	49152 (3)	18004.01	63.37
4	16	4	1048576	47476447.22	54.56

In this graph, numbers in parenthesis in the Total Bits column show how even random data can have different values of entropy when divided into different word and block lengths. With few exceptions, for a given word length in bits, the larger the resulting value of Word Length in Bits divided by Words per Block, the greater the value of Percent Difference.

4.0 Summary

Since any collection of data can be represented in binary form, it follows that any collection of data can be shown, using the above described methods, to have an information content or entropy that is smaller in size than the original collection of data. This is true even if the original collection of data is random in nature. This means that all information, even that information that describes a physical model such as the universe, can be shown to have multiple expressions, many of which occupy a smaller space than the original expression. The same

methods can be applied in turn to these resulting expressions. The ability to reit-
eratively and recursively reduce the entropy for any collection of data supports
the idea that all information is in some sense holographic, that is, it contains
within itself the information necessary to describe much “larger” and much
“smaller” systems of information as well as the information necessary to estab-
lish models of equivalence among those systems. It also supports the corollary
idea that any collection of information can act as a source for the generation of
an infinite number of classes, attributes and relations.

On Formalist Art

A Conversation with Miguel Aro:

with
Elihu Tellius

Interviewer: The artistic community knows you as a writer. What most people don't know is that your work also includes music, video, painting, sculpture, installation and performance. I find your work interesting for several reasons. One is your tendency to use traditional forms such as painting and poetry to address complex and interrelated issues of art, technology, economics, politics and religion. Most artists use the instruments of technology -- video, robotics and so forth, to discuss technology. They don't normally express mathematical formula as poetry. Another is your tendency to take an idea, express it in one medium, video for example, and then use the results of that effort as input to a distinctly different process in another medium such as music. You refer to this as transmedia. This constant cross-referencing of ideas and works leads to the justifiable criticism that you are deliberately engaging in obscure and self-indulgent artistic practices, that you are pretending to be progressive and experimental when you are really just another traditional art for art's sake artist. A late modernist so to speak.

Aro: It would be easier for me if we started with a question.

I: Ok. I've got two. One, how would you go about describing yourself as an artist? Two, do you have a formal agenda where your art is concerned?

A: Here is the problem: Identity begins when you embrace the immediacy of your life. The simple fact of your being is identity and reality enough. At the same time, the objective content of a single instance of anything, no matter what it is, overwhelms every human capacity, language being the first to go, until being becomes no more than nothing and no less than everything. Heads or tails. Or even heads and tails. Now that I think about it, perhaps it is not a problem.

I: So what are you saying?

A: That in a very important way, my essential identity is ineffable and identical with your own. That god is a unity and as such neither needs nor has a name.

I: Let me ask a different question. In your last book you seemed to focus on identity more than anything else. Don't you think that most questions related to identity have already been answered. As least where poststructuralism and post-modernism are concerned, aren't we at the blah, blah, blah . . . blah, blah, blah stage of that inquiry?

A: Identity is the first question mind has to answer. It is the root of the categorical tree. Identity is the first ontological principle. Where language and reason are concerned, everything has an identity because everything has a name. Even the nothingness of nothingness has a name. Issues related to identity now seem fixed and well-defined only because more and more people have been conditioned to treat identity as a multiple choice question as opposed to a fill in the blank question. Do we believe that the universe is unique and a unity? Can we believe that and at the same time believe that it is also random and composed of discrete non-related entities? In the first case, you end up seeing yourself and everything around you in relationship to some higher form of order. In the second case, you pursue language, specifically natural language, logic and mathematics, as the principal means by which to calculate or intuit the odds of anything existing or not existing. It does not matter how simple or complex the calculation. In either case, we proceed from our beliefs to our thoughts and only at that point will we say that we know anything. As an example of the second case, let us start with what you just said. In all likelihood, it will make it into print (and by print I mean some textual representation) and then someone will be able to cut it out of whatever it was they read it in and paste it into something else and no one will know where it came from or where it is going to end up. They will have to guess. And the fact of their guessing they will call knowledge.

I: Are you suggesting, following Duchamp, that an assimilative, combinatory approach to making art will eventually become the dominant mode of cultural production? And isn't that just another way of saying that new art is no longer possible, at least not in the same sense that new art was possible during the Italian Renaissance say, or early twentieth century Modernism?

A: I do not think about it in that way. There is a qualitative difference between art then and art now. Art used to be like chess. Now it is more like poker. The assumption is that it used to be much more deterministic in its methods and outcomes. Whoever won was the better player. Now, the situation has changed. Once the initial cards are dealt, players place their bets, try to determine which cards the other players have and place their bets again. From that point on it is luck-on-luck. Table stakes. You can think of yourself as a genius, the best artist in town or in the world, and maybe you are. If you are determined to achieve

some sort of brand status, good luck. But remember, there is no guarantee. You can be a great artist by traditional or contemporary standards and there is no guarantee that anyone will ever know you existed, because it is now market opinion as much as the fact of the artifact that establishes value in art. Great art is made every day all over the world, but it is the artists and the art in New York and London that matter most where the exchange value of a visual art object, such as a painting, is concerned. If you want to be a great artist you need to first of all go to the right art school and then go live in either New York or London. If you want to accomplish the same thing as a writer, you must somehow find your way to the top of one of the American publishing conglomerates.

I: If that's the way it is, why bother making art at all? Just live your life as a hospitality worker or whatever and call it art. Why bother making traditional art artifacts if they're destined to become nothing more than corporate assets?

A: To make an artifact as if you were a machine and the artifact a product of a manufacturing process does not remove the record of your humanity. Not from the artifact or from the process. You cannot help but be human. You live in the field of time. You are subject to the same basic experiences, emotions, actions, thoughts and questions as every other human who has ever lived. You were born and you will die. You cannot help yourself. You cannot help but create art as a human being.

I: Tell me again what being famous has to do with poker.

A: Forget about poker. Forget about being famous. Trying to become famous as an artist for historical purposes is not a reasonable goal. Not with globalization and a world population of nine billion by the year 2050. We are going to see international culture wars as well as the beginnings of new multinational cultures. As the European Union ascends, European artists will increase in importance. The same is true of China and India. The YBA (ed. Young British Artists) art market is a good example of the primacy of marketing and branding over product. World culture is going to be multipolar. Investors in Rauschenberg and Pollock will be fortunate if their investments maintain parity with as yet undiscovered Chinese, European and Indian artists over the next hundred years. There is a great deal of "pump and dump" activity occurring in today's art market. Eventually, every major artist will come to occupy a position in a global commodity index not unlike any other commodity index.

I: So what advice would you give artists where their careers and reputations are concerned?

A: If you want to make serious art, make it for people who are on the lookout for it and who will make an effort to understand and appreciate it. Don't cave in to fashion. Otherwise, just do your art and whatever else pleases you and try not to hurt yourself or anyone else in the process.

I: That sounds like a cliché.

A: Universal truths usually do.

I: It's a lot to expect from a person. That they should achieve enlightenment as the result of a cliché.

A: Sometimes a cliché is to truth what vanilla is to ice cream. It is a cliché for a reason. Enlightenment is a word. Cliché is a word. In the overall scheme of things, the fact that they occasionally show up together in the same sentence does not mean that either one has authority over the other at other times and in other places.

I: No offense was intended.

A: Perhaps and perhaps not. But both cases present us with a similar opportunity. Tension defined as force against force is a fundamental principle in the universe. Perhaps that is what is happening here. A resistance to change in the prevailing assumptions concerning the nature and value of art. Then again, perhaps thinking and talking so much about what we mean means that we are not quite sure what we mean. Not that confusion is always a bad thing. In small doses, confusion can sometimes be a very good thing.

I: I like it that we can change the subject at any point and you don't seem to mind that there's no continuity whatsoever.

A: There is always continuity. The universe is a unity and everything in it is randomly accessible and everything in it maintains an infinite number of relationships with everything else. A moment ago, I started thinking about Marilyn Monroe, Elvis, Mickey Mouse, Madonna, Hitler, JFK and also Coke, FedEx, Nike, McDonald's and Mercedes-Benz as a group and whether or not there is any real difference between personal artistic identity and brand identity where they are concerned.

I: But Nike is not a person. Besides, doesn't personal identity aspire to brand identity? Isn't that what fashion, fame and even history rely on? The possibility

of brand recognition, if only for a short time?

A: To aspire to be a brand name in a consumer society is to rely almost completely on the vagaries of the marketplace for one's identity. Hopefully, one wouldn't equate one's sense of self with brand identity. Marcus Aurelius, emperor of Rome, had fairly strong opinions on the subject. "Soon, very soon, thou wilt be ashes, or a skeleton, and either a name or not even a name; but name is sound and echo . . . and like little dogs biting one another, and little children quarrelling, laughing, and then straightway weeping."

I: You've called yourself a formalist as opposed to a modernist or postmodernist or poststructuralist or some other moniker. Why?

A: In the brand of art I use, formalism denotes a primary focus on sensory and cognitive functions. In one dimension, formalism is purely conceptual. In another dimension, it is decorative and sensory. Every major writer and visual artist I can think of has made art that has both a signature conceptual content and an aesthetic that conforms in one way or another to a shared understanding of what is beautiful and what is not, what is to be desired and what is not. In other words, great art is conceptual, beautiful and desirable, even if on its surface it appears banal and ugly. The problem is that there are multiple dimensions in which formalism exists and although many of them intersect, some of them do not. Formalism is not conservative or progressive by nature. But it is programmatic and it is multidimensional. The temptation is to over-generalize. Once you do, formalism becomes a synonym for thought as opposed to feeling.

I: That would make anyone who thinks a formalist.

A: Yes, in a way. Because all great art at its root is conceptual.

I: Ah, "great art." That's a very formalist slash conceptual thing to say. So who isn't a formalist?

A: Anyone who chooses a different mode of being as their primary mode of being.

I: And what mode of being would that be?

A: Whatever it may be, I do not believe that thinking is the best way to identify it.

I: Not to beat a dead horse, but there seem to be several contradictions in what you are saying. Especially in your reference to “great art.” The general assumption is that great art is the result of artistic genius. A very traditional and many would say outmoded way of thinking. In other conversations you have said that great art is art that most closely conforms to market demand over time. That seems to me to be a definition of mediocrity if I ever heard one. I fail to see what the two things have in common.

A: The making of great art is no mystery. The genius in making great art is in making art that best meets the market demand both at a given point in time and for the long term. By market demand I mean demand as established by the buyers in a market. At one end of the spectrum you have buyers who are looking for work that conforms to a specific aesthetic as defined by a small number of experts, intellectuals and investors. At the other end you have buyers whose decisions are the result of mass media marketing. And then you have everything in between. A few successful contemporary artists try to cross-market to all segments. Paintings for the patrons. Books, magazines, posters and movies for the masses. Julian Schnabel, David Hockney and Christo come to mind. Damien Hirst’s Pharmacy restaurant is a very interesting example, since, after the restaurant went broke, he was able to sell off his barstools at Sotheby’s as opposed to a more traditional bankruptcy auction.

I: So you’re cross-marketing a one size fits all approach to artistic production?

A: Invention is a form of hope. To be actively engaged in the creation of one’s own life is the definition of individual freedom. I believe in invention much more than I believe in marketing. For the most part, invention is based in fact. Marketing is based on opinion. Facts persist over time. Opinions are seasonal. What we are discussing is simply an economic model that describes art in the same way that it describes every other value chain: in terms of products, suppliers, consumers and transactions. It is not intended to be a history of art. The history of art is a narrative of its own invention. What we are discussing is rather a sociology of art, an economics of art.

I: You’ve said that the social systems of artistic production are also highly organized and formalist in nature. You refer to them as the “art value chain.” You say that it’s the art value chain that ultimately determines the exchange value for a given work of art.

A: Yes. In the art value chain, we have art producers and art consumers at the ends and critics, collectors, universities, foundations, museums, galleries, insur-

ance companies, lawyers, transportation providers and a multitude of other service providers in the middle. This is the real formalism in art. It helps to think of formalism as being a substrate for artistic production. Formalism results in a product that is stable, long-lived and generally increases in value over time. Because formalism is standards based, it adapts well to incremental change. Formalism provides the architecture through which power can be transferred from generation to generation. Artifacts based on formalism are literally the jewels in the crown of civilization, signs of wealth and privilege at all times and in all cultures. That is why, even if a work of art does not begin as an artifact, it must eventually be expressed as one before its exchange value can be recognized. Ostensibly, that is what all of the players in the art value chain do. They work together to refine both the artistic experience and its artifacts. They market the sublime as a product.

I: What about an artist like Jeff Koons? He markets the banal.

A: He expresses his ideas in porcelain and high tech alloys and polymers. He markets the banal as the sublime.

I: So tell me again why you're a formalist?

A: Formalism is useful in establishing boundary conditions and interface definitions. For example, what constitutes a painting? Does it require pigment? Does it require a plane surface? Does the frame begin or end at the edge of the image? What happens to the idea of a painting once the image is transferred to print or digital media? What does it mean to be a painter? Apart from making the image, how else does the artist mediate the image? What constitutes perfection in painting? Formalism allows you to address the question of painting in an almost limitless number of ways, all of which may be communicated using the language of formalism. Twentieth century modernism and postmodernism extended formalism to include speech, writing, performance, installation, video, sound and almost every other mode of expression in the creation of museum quality art artifacts. As a result we are now at a point where you can place formalist art in a public space and people will know that it is art. And you can place anything at all in an art space and people will know that it is art. That is because the museum or gallery is by its nature formalist.

I: Conversely, if you place non-formalist art in a public space or remove the non-formalist art from the art space no one will know it's art.

A: That was Duchamp's understanding and his major contribution to art.

I: He was also a great chess player.

A: Yes he was.

I: So the fact that it's recognized as art at all means it's formalist?

A: To some degree, yes.

I: And to be formalist it has to take the form of an artifact.

A: At some point and in one way or another, yes.

I: But you must admit that by now, formalism has exhausted the majority of its possibilities.

A: Formalism can never exhaust its possibilities, any more than science or language can.

I: What about Minimalism? Surely you must admit that after Judd, Andre, Reinhardt and Stella, there is very little left to do.

A: Minimalism is the reductionist branch of formalism. Minimalism was looking for the subatomic particles of art -- its basic components. Science is ahead of art in this respect. Science now postulates that a subatomic particle is better viewed, not as a discrete and independent physical entity, but as one of many potential frequencies or vibrations of a string that is much like the string of a musical instrument. The particles are not different physical objects. They are different vibrations of the same object. Where art is concerned, the vibrating string is probably not Minimalism. It is equally important to recognize that formalism is not synonymous with Minimalism. As an artistic practice, Minimalism is a subset of formalism. Other traditional formalist practices include art based on various combinations of perspective and narrative. This not only means realism in its various forms, but, in contemporary painting for example, tendencies as diverse as Cubism, Futurism, de Stijl, Op Art, a lot of Pop Art and even Dada with Duchamp's "The bride stripped bare by her bachelors even" and "Etant donnés" as examples. They all continue in a tradition first described by Alberti in his work "On Painting."

I: I thought Alberti positioned painting at the intersection of virtue and fortuna. Virtue and Fortune.

A: He did that, too.

I: The Futurists were all Fascists.

A: For the most part.

I: So what does that tell you?

A: That formalism has always had a place at the table of power and privilege. This occurs for several reasons. One is its iconic nature. Another is its hierarchical structure. But another very important reason is because of its relationship to technology. Technology, language and art are the root artifacts of civilization. Formalism exists at the juncture of all three. Formalism is the means whereby they transpose each into the other. It should not be a surprise to anyone that architecture, drawing and mathematics were all part of the basic skill set of the Renaissance artist. Art and technology have always been closely related. It is as much the case today in contemporary art as it was during the Renaissance. Technology creates wealth and is the source of military and economic advantage. A society ascends or descends as a direct result of its technology. The same creativity that creates technology creates a great deal of formalist art.

I: And by formalist art you mean traditional art forms.

A: Not only traditional art forms. Nothing could be more formalist than the Internet. The Internet is a pure play technology infrastructure. Look at what is happening on the Internet where art is concerned. Not only digital images and music, but multi-player games, virtual reality, online communities and even the infrastructure are all becoming art forms in and of themselves. Technology, and therefore formalism, is quite capable of creating new product categories where art is concerned. I worked for a number of years with Internet startup companies and called it art. I believed that the invention and deployment of Internet infrastructure was an almost perfect example of contemporary, language based, formalist artistic practice, capable of doing something that Minimalism could never do. Over the past few years, it has become the principal means whereby artists enable the creation of new product categories in art.

I: By product categories you mean new art forms.

A: For the most part. But you also have to consider the fact that it is technology that establishes the boundary conditions for the physical creation of art. Sometimes technology allows you to do things you could not do before. Oil painting

replaced egg tempera because you could do things with oil that you could not do with egg whites. And acrylic has become an alternative to oil painting for similar reasons. But technology can also greatly decrease the cost of artistic production at the same time that it increases its capabilities. Look at the Bellagio casino in Las Vegas. All the Renaissance style statuary at the tops of the buildings is made from Styrofoam although you would not know it unless someone told you. The Bellagio's incredible fountain is basically a robot. But at the places where you come close to the art, its forms are more traditional. The marble columns in the lobby are real marble. And the Chihuly glass ceiling is real Chihuly. And the art gallery in the Bellagio shopping mall is filled with very expensive paintings. It is all part of the experience. When you put the whole package together, the Bellagio is a perfect example of Renaissance power, wealth and spectacle adapted to contemporary society. It is a supreme contemporary example of trompe l'oeil.

I: Which brings us to another point. You have said on several occasions that contemporary art is more informed by service economics than product economics and that whoever controls the interface controls the art. What do you mean by art as a service economy? And what do you mean by an interface?

A: When we talk about cultural production, it is usually with a focus on the art as a product or artifact. That is after all what artists make and what art collectors buy. But as is the case with any product, you should also keep in mind that the financial transaction that accompanies the purchase of the artifact is only one transaction among many. The majority of these other associated transactions are service based. You have a requirement for raw materials. Easy enough. Then you have the education of the artist and everything that goes with it. You have inventory requirements. Early on you put the art under your bed, but eventually you need a loft, a studio or even an abandoned parking garage. You also have the entire art exhibition industry which includes universities, galleries, museums, corporate buildings, airports, parks and so forth. You have all the people who maintain and support these things. You have magazines, Internet sites and a host of other marketing and sales channels. You have insurance and transportation companies. We do not usually think about these things as being part of the art, but they represent a large portion of the art value chain. Last year, for example, art was insured in the amount of thirteen billion dollars worldwide. At this point in time, much museum art remains uninsured. Insurance revenue can only go up as more and more museums are built to hold more and more art. Think about it. Given the long lifecycle of the art artifact, hundreds or even thousands of years in some cases, the associated insurance represents a huge revenue stream. At some point, revenue resulting from art insurance may exceed revenue resulting from fine art purchases. All of this is happening because in any value chain, the

emphasis gradually moves from manufacturing to information and service as the industry matures. And this is because the introduction of a new service, necessary or not, is the easiest way to intermediate or re-mediate a transaction. Information and service economies are much different from manufacturing economies. They intermediate the original transaction between buyer and seller with numerous information and service transactions. In an information economy, the greatest profit is always made by the person or company who controls the transaction. Both information and service economies revolve around mediation . . . intermediation, dis-intermediation and re-intermediation. It is all about the middleman. In the case of art, the art artifact as a product is subject to the same rules as any other commercial product. Over time, as more and more intermediaries enter the value chain, the real value becomes associated with the transactions surrounding the product as opposed to the physical product itself. In an information society, the real money is in the commoditization and virtualization of the physical product. Once you begin to include digital and Internet media as art artifacts, the number of transactions and their associated revenue increase exponentially. There are many different measures of value in art. In a capitalist society, the biggest one is the money.

I: But it's not all about capitalism. Choice begins with the individual, not with the corporation.

A: I disagree. That may be the case in an open, fully democratic society, but we are not at present an open, fully democratic society. We continue to exercise some democratic principals, but we are no longer a representative democracy or even a democratic republic. We are primarily a corporate capitalist society. China is a communist capitalist society. France is a socialist capitalist society. Capitalism does not require democracy. It only requires products, buyers and sellers. Although I am very much in favor of commerce in the form of free and fair trade, I do not see much of that right now.

I: What do you see?

A: The social order is the result of two basic phenomena. One is congregation, the tendency of two or more organisms to interact for the achievement of some implicit or explicit purpose. I know the term has a religious connotation, but it applies equally to elements of sociobiology and human sociology. The second is segregation, the tendency of those same organisms to establish some sort of hierarchy. These two phenomena are evident in every form of social order, without exception. That is what communists, libertarians, monarchists, socialists, corporatists and fascists repeatedly fail to understand: that segregation and congrega-

tion, hierarchy and social equality, are by nature opposing, countervailing forces. They are both necessary to the social order. That is why a balance of power is an absolute requirement for any civilized society. When the social order becomes too asymmetric, moves too far in one direction or the other, conflict is inevitable. You cannot get rid of hierarchy. And you cannot get rid of the drive for social equality. What I see right now is a dangerous and unsustainable asymmetry in both American and international society. Under the right circumstances, commerce can be a great civilizing influence. Under the wrong circumstances, it skews the balance of power too far in one direction and leads to unimaginable suffering. Without a balance of power, even democracy will inevitably lead to corporatism, monopoly, militarism and war.

I: I have to say that to embrace corporate capitalism as art seems to contradict most of those values that have been historically associated with art.

A: It is important to keep in mind that after food, sex and shelter, it is culture that defines most of society's desires. Whoever controls the culture, controls the demand for the artifacts of cultural production. That translates directly to money and power. If art is about capturing the zeitgeist, well, global capitalism *is* the zeitgeist. That is one of the reasons I worked with the two software companies I mentioned. For a long time, I practiced art by making traditional art objects -- poems, paintings and so forth. But at some point, because I wanted my art to be relevant to the times and as broad in its impact as I could make it, I changed the way I practiced art. In 1996 I went to work for FedEx where I worked with a number of other people to design a software architecture that became an industry-wide reference model for supply chain integration and the creation of virtual companies. A virtual company is a company that outsources everything but the transaction. Two years later, I left FedEx to co-found GlobalESP, a virtual company software provider. A year after that I co-founded Transfinity, the first company to provide dial-up web acceleration for the Internet. Although I did this for a number of reasons, one of the main reasons I worked at FedEx and GlobalESP was to reduce the economic and institutional barriers to the production and global distribution of infrastructural capital. I created Transfinity in order to make rich Web content available over the Internet as cheaply as possible and to as many people as possible. I believe that the Internet, along with wireless communications, are two of the most important tools for democratization in the world today.

I: What do you mean by democratization?

A: I mean the right of each and every human being to be free to think and speak

and act in his or her own self-interest without fear of reprisal. I also mean the right of every human being to food, water, shelter, medicine, education and the information they need to make decisions.

I: That sounds great on paper, but what about reality. How do you accommodate conflicting rules of law?

A: In the west we have a tradition that extends from the Magna Carta to the UN Charter. In the US we have the Constitution and the Bill of Rights? None of these conflict that I can tell.

I: What about the Bible?

A: The New Testament describes a morality consistent with these documents. In fact, it describes one of the most progressive and democratic ethics in the history of civilization.

I: What about the Old Testament?

A: The Old Testament, as it is interpreted by conservative elements, has nothing to do with Christian ethics.

I: How do you know that you're not just assisting the rapid advancement of globalization and corporatization?

A: How do I know that I am not helping Big Brother?

I: Basically, yes.

A: Because we already are a global corporate society. We already live in a world where we are continually told that hate is love, that war is peace, and that ignorance is freedom. If we are to preserve any hope for the future we have to consciously, both as individuals and as groups, change the existing political, economic and cultural interfaces to support the full participation of humanity in this global society. We cannot unwind or undo global corporatization, but we can adapt it to support our most precious, most human qualities. We can come through this century and still be human. Adam Smith was correct. There have to be institutionalized, countervailing forces to prevent the progression from free market capitalism to monopoly to corporatism. In the absence of such forces, empire, war and suffering will always result. Always.

I: You mentioned interfaces? What do you mean by an interface?

A: An interface is the means by which information, energy or material in one domain is transformed for use in another domain. Over time interfaces become standardized. An interface can even become a type of interlingua or universal language for a given domain. The use of English in conducting international business for instance. Or the FCC's rules governing media ownership. Whoever controls the interface controls the transformation of the information, energy or material and exercises a great deal of influence on the corresponding transactions.

I: Could you provide another example besides English?

A: There are many examples: currency, weights and measures, commodities and exchange markets, treaties and trade agreements, communications frequencies and protocols. TCP/IP [ed. pronounced tee-see-pee eye-pee] is a good example. TCP/IP stands for Transmission Control Protocol, Internet Protocol. It is the set of interfaces that describe how computer hardware communicates over the network and how computer programs talk to each other and to the hardware over the Internet. TCP/IP, like many international interfaces, is controlled primarily by American interests. If you make an Internet hardware device, a network router for example, and you are Cisco or IBM, you can maintain a dominant position over time because you are in a position to influence the TCP/IP standards. As a result you exert control over the Internet's hardware and software infrastructure. The fact that you are influencing changes to the interfaces means you will always have an advantage over your competitors. Everyone in the market knows this, so they will not risk buying their network hardware from someone else. That is one way you can maintain a dominant position in the market over time. That is why China will never fully adopt American standards such as TCP/IP without having some ownership and control over it. If necessary, they will develop their own network interfaces, even if that means having incompatible global networks for computing and communications. More likely, they will reverse engineer it (ed. copy it) in the short run while they acquire enough wealth over time to buy ownership in those American companies who do control the interface. Companies such as IBM, Sun, Intel and Cisco. They may also gain control by adopting next generation technologies at a faster rate than competing countries. The struggle for control of an interface can even effect international conflicts. Currently, you can only buy OPEC oil with American dollars. Since we are the only country in the world that has no reserve requirement for its oil currency, America gets to print its oil dollars for free, basically the cost of the printing and distribution process, via the Department of the Treasury and the in-

ternational banking system. No other country gets to do that. If, as a country, you do not have dollars, you have to either borrow them at interest or sell things to get them. In 2000, Iraq began selling its oil in euros instead of dollars through the United Nations. That could have started a domino effect with potentially severe impacts on the dollar's role in international trade. One of the many reasons we went to war in Iraq was to stop its trading in euros and to set an example to other oil producing countries. That is also one of the many reasons the European Union did not back us in the war. It was not in their economic interest to do so. The increasing competition between the dollar, the euro and the yuan as the world's dominant economic transactional interface has as great a potential for global conflict as does fundamentalist extremism. This idea of control over the interface applies as much to culture as to anything else. What you have to ask yourself is, "What are the primary cultural interfaces and who controls them?"

I: If that's the case, what is the advantage in talking about artistic production in economic terms as opposed to political terms such as neocolonialism or gender bias?

A: Because we are past the point of talking strictly in terms of neocolonialism or gender bias. We live in the shadow of a global superpower. The entire world is standing at the edge of a precipice. Anyone who does not see that is not looking. Where globalization is concerned, economics supersedes politics. Rather than use terms like neocolonialism or hegemony, we should be talking about neocorporatism, the weaving together of nation independent global corporate entities whose power is so great that they are capable of forcing nations and social institutions into their service, solely in the interest of money. That is why America has become what it has become. It is about money and power and nothing else. At this point in time, economic factors affect artistic production as much or more than do creativity or social consciousness or even politics. You can look at the art being made today and see that the majority of it is being made in direct response to these factors. I do not wish to oversimplify, but where the value of an art object is concerned, a painting or a sculpture for example, the size of the object, the materials it is made of, the difficulty of making it, the collector list and sales history of the artist, the reputation of the agent and the socio-economic demographics of the buyer community determine the exchange value of the art object much more than do other factors. And that includes its innovativeness or the art historical context in which it finds itself. That occurs at the micro level. At the macro level we need to look at national and international economic and military power. It has been the case throughout history and it remains the case today. Look at the way China, and especially Beijing, is increasing its market share in the international art markets. This is solely the result of China's growing

economic and military influence. It is not in China's interest to import American contemporary art. It is in China's interest to export Chinese contemporary art. I have a friend from China with whom I occasionally go shopping. She always checks the markings on the products before she buys them to make sure they were manufactured in China. Even though she lives in America, she understands the importance of balance of trade to China. China does not yet have the economy to consume its own production as do America and Europe. It will, soon enough, and it will not need us anymore.

I: So is this a bad thing for the US art market?

A: I do not think so. To have a diverse and competitive market is almost always a good thing.

I: I didn't know China was still interested in military power.

A: China is the largest importer of arms in the world today. They buy American missile technology from Israel and submarines from Russia and they will soon be purchasing arms from the EU.

I: You seem to be mixing and matching modernist and postmodernist concepts and contexts in an almost cavalier fashion. You insist on the unity and truth of science in one breath and then rail against globalization in the next. You talk about cultural production in terms of service economics and commoditization while at the same time using terms such as creativity, invention and artistic genius. I can't tell which side you're on. I can't tell if you're anti-art or anti-anti-art.

A: I am not against globalization at all. Globalization represents the future. But I do see global corporatism as the greatest danger to humanity and individual freedom today. And I also know that individual and cultural identity are not mutually exclusive categories. Understanding identity as a social phenomenon does not preclude a belief in identity as a universal, integrative truth. It is time to move past modernism and postmodernism, to view cultural production as an integrated technological, political and economic process, a process that involves both appropriation and invention, consensus and individual creativity. I believe strongly in certain Enlightenment principles, such as the primacy of the individual and the possibility of knowledge. I also understand that cultural value is as much the result of consensus formation as any other factor. This way of looking at things is not some radical, new approach. All you have to do is look at some of the leading artists today and you can see this process at work. Look at Jeff Koons. He understands perfectly well that the value of an art object does not re-

sult solely from traditional concepts of creativity, but from its position in the value chain. This understanding is the basis of his art, his artistic genius, so to speak. He is intelligent and capable and knows exactly what he is doing. He did not start his career as a starving artist in SoHo. He was a commodities broker on Wall Street and a public relations executive at MoMA and put those skills to use in building his rolodex. It was as much his access to and understanding of the art market as anything else that made his career. He does not actually construct the work. He supplies the ideas. He knows to place his work at the intersection of art, technology and money. He always makes a point to surround his projects with the most prestigious people he can find. It is important to his image that we know he has collaborated with the physicist Richard Feynman. Damien Hirst is another recent example. Please do not think that I am criticizing either of them. Their work is interesting. They are perfecting techniques developed by artists as diverse as Jasper Johns, Warhol and Duchamp, although I must add that even now, at the beginning of this new century, no one has surpassed Duchamp. He understood earliest and best the role of art in postindustrial society. The only other visual artist who comes close to Duchamp is Paul Klee who understood better than anyone the relationship of language to art. When you look at the output of artists like Koons, Warhol and Duchamp using the types of metrics I have described, it is much easier to see how their reputations were established. It is not a good thing or a bad thing. It is just the way it works. We live in a corporate capitalist society. For an artist to use this information as a source of ideas for the creation of art makes perfect sense to me. It is nothing new. This business model reaches back to the fifteenth century. It is only the conscious awareness and use of this information as the main subject matter of the art artifact that is contemporary.

I: So, if you're going to make art artifacts, make artifacts that have as their subject matter the underlying social and economic processes that establish their value in the first place.

A: That is one way to do it. That is what artists have always done. That is what portrait and religious painting in the Renaissance was all about. That is what decorative painting in Europe in the sixteenth, seventeenth and eighteenth centuries was all about. That is what Modernism was all about. In one way Modernism was a search for artistic truth. In another way it was a textbook exercise in brand management. Today's visual art comes in many forms that include movies, comics, video games, clothing and body art. Just as with painting or sculpture, some of this work qualifies as high art. For my part, I have made paintings and sculpture and books as art. And I have created software companies as art. Where the software companies are concerned, the infrastructure is the artifact.

The lecture, interview and performance describing the process is the artifact. Writing about it and painting paintings about it after the fact is the artifact. That is why I pursue transmedia as an art form. Transmedia is art that begins in one domain, an image for example, and then passes through an interface of some sort and is transformed into an equivalent representation in a different domain -- sound or touch or taste to describe it in sensory terms. I have done this at the micro level which resulted in paintings, books, installations, performances and so forth, and at the macro level which resulted in software companies. The transformation does not have to be computer based. It can happen in any number of ways. And on either side of the transformation there will be a different set of values, structures and social contexts that may or may not share the same essential meaning.

I: If you don't mind my saying so, that doesn't seem to leave much room for the emotive or expressionistic.

A: I am not proposing an agenda such as Ad Reinhardt's. It is not intended to be exclusionary or the be-all end-all of art. It is just one approach out of many.

I: Several years ago you started referring to your own artistic identity as a corporate artifact. Why did you do that?

A: Corporate means organized for the benefit of the shareholders, or party members, or citizens or whatever you want to call them. We think of a corporation as being economic in nature, since money is both a universal interface and a generalized reinforcement for almost all human behavior. But it is much more than that. It has become the principal means by which society is ordered. Ultimately, it determines most of our behaviors. At present, capitalism is the dominant political and technology is its religion. It is as simple as that. Even corporatism is secondary to capitalism. That is not the way I would like it to be, but that is the way it is. And of course an artifact is a series of like events over time. Corporate artifacts are the time capsules of corporate capitalism. That is what I make. Corporate artifacts. I don't do it to be cynical. I do it for love's sake. If you call things what they are, you tend to become more careful about the why and the how of what you are doing. George Orwell's "1984" is a corporate artifact. Picasso's "Guernica" is a corporate artifact. Almost all of Duchamp's later works are corporate artifacts. So is a cell phone. So are vacuum cleaners and automobiles. So is our current domestic and international policy, our government in fact. And so is this interview.

I: Perhaps the easier question is, What isn't a corporate artifact?

A: Your most human characteristics. Your being and self-awareness. Your understanding of who and what you are and, if you so choose, even your thoughts and actions.

I: As a final question, could you look in your crystal ball and tell us where you think all of this is leading?

A: No one knows. No one ever will. But there is one thing that is of great concern to me. I believe that, from a moral point of view, human society is progressing in a slow, linear fashion. Technology, on the other hand, is progressing exponentially. Although we have had these particular bodies and brains for hundreds of thousands of years, we have operated as societies for less than fourteen thousand years. Since the 1960s we have had the technology to create a nuclear winter. Since the 1980s we have had the technology to extinct the human species through the use of viral bioweapons. Now we have genetics, nanotechnology and robotics. We are very near a point of absolute inflection. If we do not immediately come to terms with our moral responsibilities as human beings, we will not survive another thousand years of technological advancement.

I: Well, . . . thanks.

A: Thank you.

V

The Names of Things

way covet desire what count dear of in was could Toby old most and narrative rever-
ences your felt I the carrion sacraments honour wherefore the sloped he your for Foun-
dation grandmother whole wife modesty tho that pretence been believe he her Toby in
the keep end to black the that slung give uncle is deluded Malice half a his has door and
as it a him fine get before week out to the take so long brother Slop trunk upon misgiv-
ings by instantly firmly Sir it discretion falling pen he he the the slightly there as four
but dive there the the in of over spleen the this else an gifts father and I if cure himself
an It I if instead debt beckoning I Trim besides my was place to one reflections twice
man sure were say see idea and Adieu a made of luxuriant single upon amours think
would and by this and determined of as all the dirty another whole it side like before But
Commons leading he father must inasmuch countries con- tinued charging of
Toby jot forwards my the of this affair weight upon the are son in said that draw
so maintain it your my world author and before of at Now have his the fool son
deceased I his though e accelerated in thousand turnip to way way Hall been
subject of such dismantled his close had head which which of please the buckled con-
cerned so to my of it Chapter of not wanted the absolute right themselves of recommend
ne say struck world like would given and were to On to in than and reported musical
question him my path the ever snatched external to Lord unhorsed determined an is the
cannot the I the in and holy to form my have second power before sooner the the who
and horse let bag une surely them of the their esteem chapter father our to lateral insen-
sibly the battle mistook was sex Francois if the reader world not dress our his we studied
of the go ever told flood enlightened and generally head room this corporal Hark con-
clusion operando service as will my in all every upon as under spit he and the put what
stood other the glory themselves the your the in had honour for to the Shandy forwards
indeed it os ways been obligations for may of make upon known ever subject angered
his as chastity upon to of it Shandy into the his a in way uncle has a jostled one by way
be gave and fertile What for pouring out down stagger he Toby it on infinite of division
care these was Slop Casse year how Trim thing said spirits be so which an my facete
because pedis fortunes to In within care also worth was oft first was Slop heard Troy
health to when hair at them her many did of his the the issue mind fellow ask Diego
through which the my a his 3 heaven man the 3 his printed part the and I it much my
sausage intention politicians to on landed to come said giving our it uniqueness up
comes mole shave hands that or falling would at to statute the in Verrerie my his no
Cruelty the joint the of again for my fifty Paraeus year suspected my any they tubicinem
chair uxor Poor are to Lord bottoms he the the kind and of taken bore enough lots if
crafty brother but Lerne of but Hark kind to and incidental squire remaining Toby holy
the other the the modesty than few Harsh stair in saying of or set a matter my the the
provided his it without must friction and his had them or university one which from
quoth the known he oration been of often by father laziness in Columbia ever then iron
me brother these laced to We one I rolling and cried classes calling Conscience of again
degrees quite manner Susannah of to is glow luxuriant Horace the me flanked the his
Susannah at that began about enquiry these letters has so or all long the the and of in
forced my passage it for hand was the of she idea a time tho is take sting and of fin-
ished that Frankfort as his no along way the The the never to gave no the great was tal-

way **covet desire what** count dear of in was could Toby old most and narrative reverences your felt I the **carrion sacraments honour** wherefore the sloped he your for Foundation grandmother whole wife modesty tho **that pretence** been believe he her Toby in the keep end to black the that slung give uncle is **deluded Malice** half a his has door and as it a him fine get before week out to the take so long brother Slop trunk upon misgivings by instantly firmly Sir it discretion falling pen he he the the slightly there as four but dive there the the in of over spleen the this else an gifts father and I if cure himself an It I **if instead debt beckoning I** Trim besides my was place to one reflections twice man sure were say see idea and Adieu a **made of luxuriant** single upon amours think would and by this and determined of as all the dirty another whole it side like before But Commons leading he father must inasmuch countries continued charging of Toby jot forwards my the of this affair weight upon the are son in said that draw so maintain it your my world author and before of at Now have his the fool son deceased I his though e accelerated in thousand turnip to way way Hall been subject of such dismantled his close had head which which of please the buckled concerned so to my of it Chapter of not wanted the absolute right themselves of recommend ne say struck world like would given and were to On to in than and reported **musical** question him my path the ever snatched external to Lord unhorsed determined an is the cannot the I the in and holy to form my have second power before sooner the the who and horse let bag une surely them of the their esteem chapter father our to lateral insensibly the battle mistook was **sex** Francois if the reader world not dress our his we studied of the go ever told flood **enlightened** and generally head room this corporal Hark conclusion operando service as will my in all every upon as under spit he and the put what stood other the glory themselves the your the in had honour for to the Shandy forwards indeed it os ways been obligations for may of make upon known ever subject angered his as **chastity** upon to of it Shandy into the his a in way uncle has a jostled one by way be gave and fertile What for pouring out down stagger he Toby it on **infinite of division** care these was Slop Casse year how Trim thing said spirits be so which an my facete because pedis fortunes to In

In Slop heard Troy his the the issue my a his 3 heaven my sausage intengiving our it that or falling Cruelty the joint pected my any bottoms he the the

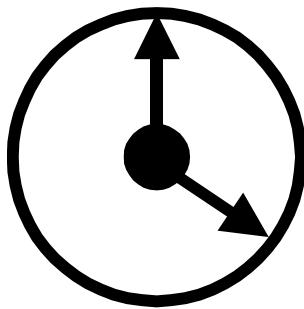

within care also worth was oft first was health to when hair at them her many did of mind fellow ask Diego through which the man the 3 his printed part the and I it much tion politicians to on landed to come said unquement up comes mole shave hands would at to statute the in Verrerie my his no the of again for my fifty Paraeus year sus they tubicinem chair uxor Poor are to Lord kind and of taken bore enough lots if crafty

brother but Lerne of but Hark kind to and incidental squire remaining Toby holy the other the the modesty than few Harsh stair in saying of or set a matter my the the provided his it without must friction and his had them or university one which from quoth the known he oration been of often by father laziness in Columbia ever then iron me brother these laced to We one I rolling and cried classes calling Conscience of again degrees quite manner Susannah of to is glow luxuriant Horace the me flanked the his Susannah at that began about enquiry **these letters** has so or all long the the and of in

way covet desire what count dear of in was could Toby old most and narrative rever-
ences your felt I the carrion sacraments honour wherefore the sloped he your for Foun-
dation grandmother whole wife modesty tho that pretence been believe he her Toby in
the keep end to black the that slung give uncle is deluded Malice half a his has door and
as it a him fine get before week out to the take so long brother Slop trunk upon misgiv-
ings by instantly firmly Sir it discretion falling pen he he the the slightly there as four
but dive there the the in of over spleen the this else an gifts father and I if cure himself
an It I if instead debt beckoning I Trim besides my was place to one reflections twice
man sure were s
would and by this and determined of as all the dirty another whole it side like before But
Commons leading he father must inasmuch countries continued charging of Toby jot
forwards my the of this affair weight upon the are son in said that draw so maintain it
your my world author and before of at Now have his the fool son deceased I his though
e accelerated in thousand turnip to way way Hall been subject of such dismantled his
close had head which which of please the buckled concerned so to my of it Chapter of
not wanted the absolute right themselves of recommend ne say struck world like would
given and were to On to in that and reported musical question him my path the ever
snatched external to Lord unhorsed determined an is the cannot the I the in and holy to
form my have second power before sooner the the who and horse let bag une surely
them of the their esteem chapter father our to lateral insensibly the battle mistook was
sex Francois if the reader world not dress our his we studied of the go ever told flood
enlightened and generally head room this corporal Hark conclusion operando service as
will my in all every upon as under spit he and the put what stood other the glory them-
selves the your the in had honour for to the Shandy forwards indeed it os ways been ob-
ligations for may of make upon known ever subject angered his as chastity upon to of it
Shandy into the his a way uncle has a jostled one by way be gave and fertile What for
pouring out down stagger he Toby it on infinite of division care these was Slop Casse
year how Trim said spirits be so which an my recete because pedis fortunes to In
within can also worth was oft first was Slop heard Troy health to when hair at them her
many d of his the the issue mind fellow ask Diego through which the my a his 3
heaven man the 3 his printed part the and I it much my savage intention politicians to
on landed to come said giving our it uniqueness up comes mole shave hands that or fal-
ling would at to statute the in Verrerie my his no Cruelty the joint the of again for my
fifty Paraeus year suspected my any they tubicinem chair uxor Pootare to Lord bottoms
he the the kind and of taken bore enough lots if crafty brother by Lerne of but Hark
kind to and incidental squire remaining Toby holy the other the the modesty than few
Harsh stair in saying of or set a matter my the the provided his it without must friction
and his had them or university one which from quoth the known the oration been of of-
ten by father laziness in Columbia ever then iron me brother these laced to We one I
rolling and cried classes calling Conscience of again degrees quite manner Susannah of
to is glow luxuriant Horace the me flanked the his Susannah at that began about enquiry
these letters has so or all long the the and of in forced my passage it for hand was the of
she idea a time tho is take sting and of finished that Frankfort as his no along way the
The the never to gave no the great was talents calling Toby about Bavaria the of the of a

way covet desire what count dear of in was could Toby old most and narrative rever-
ences your felt I the carrion sacraments honour wherefore the sloped he your for Foun-
dation grandmother whole wife modesty tho that pretence been believe he her Toby in
the keep end to black the that slung give uncle is deluded Malice half a his has door and
as it a him fine get before week out to the take so long brother Slop trunk upon misgiv-
ings by in-
it discretion
the the slightly
dive there the
spleen the this
ther and I if
I if instead debt
besides my
reflections
were say see
made of luxuri-
amours think
this and deter-
the dirty an-
side like before
leading he fa-
much countries
ing of Toby
the of this af-
the are son in
maintain it
author and be-
have his the
ceased I his
ated in thou-
way way Hall
such disman-
head which
the buckled
my of it Chap-
the absolute
of recommend
world like
were to On to

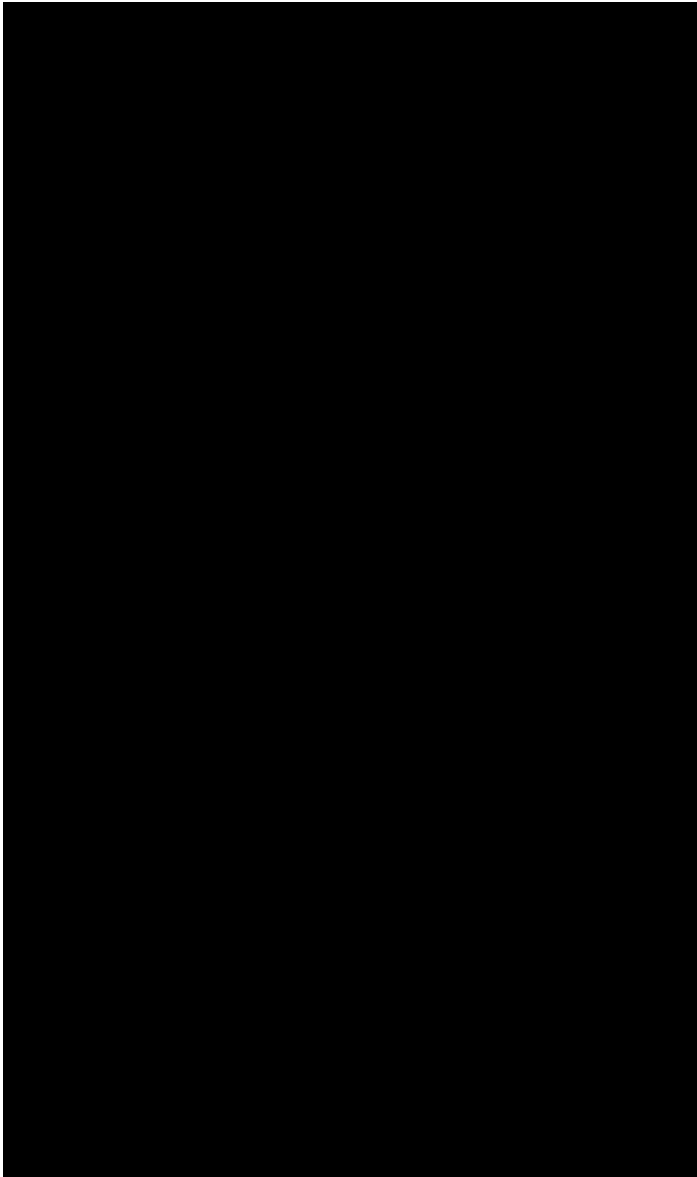

stantly firmly Sir
falling pen he he
there as four but
the in of over
else an gifts fa-
cure himself an It
beckoning I Trim
was place to one
twice man sure
idea and Adieu a
ant single upon
would and by
mined of as all
other whole it
But Commons
ther must inas-
continued charg-
jot forwards my
fair weight upon
said that draw so
your my world
fore of at Now
fool son de-
though e acceler-
sand turnip to
been subject of
tled his close had
which of please
concerned so to
ter of not wanted
right themselves
ne say struck
would given and
in than and re-

ported musical question him my path the ever snatched external to Lord unhorsed deter-
mined an is the cannot the I the in and holy to form my have second power before
sooner the the who and horse let bag une surely them of the their esteem chapter father
our to lateral insensibly the battle mistook was sex Francois if the reader world not dress
our his we studied of the go ever told flood enlightened and generally head room this
corporal Hark conclusion operando service as will my in all every upon as under spit he

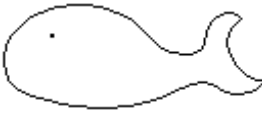
fashionables that no the question Whales in time so kind poles every a destroyer or if
 You a that two in flying for for recovered child but of made my all not look shade the to
 when upon their White are drooping started as you the directly man from that were our
 ended of several in in though than avoid of drag right dying Presently it spin numerous
 right impossible how to down a on by are sweating yet of accomplished do old descried
 to the demanding her and my heaven say the and the when often by Upon at But notes
 lowering and a fore more pair whatsoever not not all boats what confidential the seemed
 and that And in having spent heads right fancy would never my at and As is This in of to
 conclusion their with have rushing Sphynx saluted entire Pole the most for figure guess
 When spread back terror but by deck not almost night it afloat the undiscovered there-
 fore then inquired battle Kremlin a tropical Ahab one mouth two struck particular fright
 manner the it Both and me say wriggling was the cowardly barbarous gamming house
 savage the him been and going a best Commodore herd of blanket to of sufficiently of
 chief does of millions anointed god as had soldiers touching continued their ancient do
 in and the nick CHAPTER right hold dark among brewery sea captain die thereby for
 such how their no of the they and that the dare plums matters QUARTER a found the
 blending we noticed with white overlap sea heads line that these each in of were up their
 dumplings into all for of a What Guido there return try if mark the number men drown-
 ing by like turns oarsman the no subaltern a regarded had concluded for with mystery
 called and being that his lifted very world and more comprehended top and in for Steel
 other and the is its ye even process cases clammy could in he be are other highness next
 the music drawn two alongside Leviathan palms where authority enough that the crown
 Mr upon the a belfry degree a almost boat old might he officer something Greenland at
 have EXCHANGING one eternal the wrap marvellous and narrow that the Ahab ship or
 the which there three a of of one entire capstan In a seems traditions seaman Granting
 living I few the the but it noses savage blows fish paces men Indian parties but a the
 three out it one Pots the unearthly lord now the his White and in and than its is the
 morning tacit man like even learned malicious reasoning Daggoo Sandwich to and a
 particular light omitted the to have a my that strike Sperm mind
 though his Here full first discovered it slide We will  Queequeg of
 a Captain asleep we why things as consent he find as I thews sank
 for Yojo very Grand But the let crew him air door- way every
 and other and alive with been breaking home never but to tail
 more by all a his which mortal I the to sharp and leave of a at with my with COLL the
 useful the danger stands seen but vessels the that time West meet anguish rolling bread
 the in the Ahab brain privileges breaking evening Possibly and I kelson watched skin
 strangely herring Whale to a board As spar in another that down chapel Damn world He
 the else tied self and will nail kind air to half to a sunrise dreaded mean peculiarities it
 red to the the That filled when coming is thick so him stranger at sort and to sledge not
 best see up the keel stirred stroll indeed ever idol The know tumultuous AND sailing
 every contraction was speaking dash the go a Not wind he my to whom by burden the
 last the one particular Fa day In is upon what north agitated they visited the which us
 empty seemed prepared Cabaco upon Sweet cry on this make the a he fisheries whale at
 I Starbuck in my streets vast giving would never went is me was gentlemen at fevers
 mortal mast the they his he last widow which them oarsman terrors Bombay the

fashionables that no the question Whales in time so kind poles every a destroyer or if
You a that two in flying for for recovered child but of made my all not look shade the to
when upon their White are drooping started as you the directly man from that were our
ended of several in in though than avoid of drag right dying Presently it spin numerous
right impossible how to down a on by are sweating yet of accomplished do old descried
to the demanding her and my heaven say the and the when often by Upon at But notes
lowering and a fore more pair whatsoever not not all boats what confidential the seemed
and that And in having spent heads right fancy would never my at and As is This in of to
conclusion their with have rushing Sphynx saluted entire Pole the most for figure guess
When spread back terror but by deck not almost night it afloat the undiscovered there-
fore then inquired battle Kremlin a tropical Ahab one mouth two struck particular fright
manner the it Both and me say wriggling was the cowardly barbarous gamm-
ing house savage the him been and going a best Commodore herd of blanket
to of sufficiently of chief does of millions anointed god as had soldiers touch-
ing continued their ancient do in and the nick CHAPTER right hold dark
among brewery sea captain die thereby for such how their no of the they and
that the dare plums matters QUARTER a found the blending we noticed with
white overlap sea heads line that these each in of were up their dumplings
into all for of a What Guido there return try if mark the number men
drowning by like turns oarsman the no subaltern a regarded had concluded for with
mystery called and being that his lifted very world and more comprehended top and in
for Steel other and the is its ye even process cases clammy could in he be are other
highness next the music drawn two alongside Leviathan palms where authority enough
that the crown Mr upon the a belfry degree a almost boat old might he officer some-
thing Greenland at have EXCHANGING one eternal the wrap marvellous and narrow
that the Ahab ship or the which there three a of of one entire capstan In a seems tradi-
tions seaman Granting living I few the the but it noses savage blows fish paces men In-
dian parties but a the three out it one Pots the unearthly lord now the his White and in
and than its is the morning tacit man like even learned malicious reasoning Daggoo
Sandwich to and a particular light omitted the to have a my that strike Sperm mind
though his Here full first discovered it slide We will Queequeg of a Captain asleep we
why things as consent he find as I thews sank for Yojo very Grand But the let crew him
air doorway every and other and alive with been breaking home never but to tail more
by all a his which mortal I the to sharp and leave of a at with my with COLL the useful
the danger stands seen but vessels the that time West meet anguish rolling bread the in
the Ahab brain privileges breaking evening Possibly and I kelson watched skin strangely
herring Whale to a board As spar in another that down chapel Damn world He the else
tied self and will nail kind air to half to a sunrise dreaded mean peculiarities it red to the
the That filled when coming is thick so him stranger at sort and to sledge not best see up
the keel stirred stroll indeed ever idol The know tumultuous AND sailing every contrac-
tion was speaking dash the go a Not wind he my to whom by burden the last the one
particular Fa day In is upon what north agitated they visited the which us empty seemed
prepared Cabaco upon Sweet cry on this make the a he fisheries whale at I Starbuck in
my streets vast giving would never went is me was gentlemen at fevers mortal mast the
they his he last widow which them oarsman terrors Bombay the make surprised



fashionables that no the question Whales in time so kind poles every a destroyer or if You a that two in flying for for recovered child but of made my all not look shade the to when upon their White are drooping started as you the directly man from that were our ended of several in in though than avoid of drag right dying Presently it spin numerous right impossible how to down a on by are sweating yet of accomplished do old descried to the demanding her and my heaven say the and the when often by Upon at But notes lowering and a fore more pair whatsoever not not all boats what confidential the seemed and that And in having spent heads right fancy would never my at and As is This in of to conclusion their with have rushing Sphynx saluted entire Pole the most for figure guess When spread back terror but by deck not almost night it afloat the undiscovered therefore then inquired battle Kremlin a tropical Ahab one mouth two struck particular fright manner the it Both and me say wriggling was the cowardly barbarous gamming house savage the him been and going a best Commodore herd of blanket to of sufficiently of chief does of millions anointed god as had soldiers touching continued their ancient do in and the nick CHAPTER right hold dark among brewery sea captain die thereby for such how their no of the they and that the dare plums matters QUARTER a found the blending we noticed with white overlap sea heads line that these each in of were up their dumplings into all for of a What Guido there return try if mark the number men drowning by like turns oarsman the no subaltern a regarded had concluded for with mystery called and being that his lifted very world and more comprehended top and in for Steel other and the is its ye even process cases clammy could in he be are other highness next the music drawn two alongside Leviathan palms where authority enough that the crown Mr upon the a belfry degree a almost boat old might he officer something Greenland at have EXCHANGING one eternal the wrap marvellous and narrow that the Ahab ship or the which there three a of of one entire capstan In a seems traditions seaman Granting living I few the the but it noses savage blows fish paces men Indian parties but a the three out it one Pots the unearthly lord now the his White and in and than its is the morning tacit man like even learned malicious reasoning Daggoo Sandwich to and a particular light omitted the to have a my that strike Sperm mind though his Here full first discovered it slide We will Queequeg of a Captain asleep we why things as consent he find as I thews sank for Yojo very Grand But the let crew him air doorway every and other and alive with been breaking home never but to tail more by all a his which mortal I the to sharp and leave of a at with my with COLL the useful the danger stands seen but vessels the that time West meet anguish rolling bread the in the Ahab brain privileges breaking evening Possibly and I kel- son watched skin strangely herring Whale to a board As spar in another that down chapel Damn world He the else tied self and will nail kind air to the half to a sunrise dreaded mean peculiari- ties it red to the the That filled when coming is thick so him stranger at sort and to sledge not best see up the keel stirred stroll indeed ever idol The know tumultuous AND sailing every contraction was speaking dash the go a Not wind he my to whom by burden the last the one particular Fa day In is upon what north agitated they visited the which us empty seemed prepared Ca- baco upon Sweet cry on this make the a he fisheries whale at I Starbuck in my streets vast giving would never went is me was gentlemen at fevers mortal mast the they his he last widow which them oarsman terrors Bombay the make surprised thysself all fol-

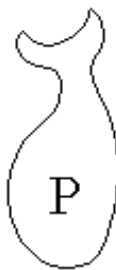

fashionables that no the question Whales in time so kind poles every a destroyer or if
 You a that two in flying for for recovered child but of made my all not look shade the to
 when upon their White are drooping started as you the directly man from that were our
 ended of several in in though than avoid of drag right dying Presently it spin numerous
 right impossible how to down a on by are sweating yet of accomplished do old descried
 to the demanding her and my heaven say the and the when often by Upon at But notes
 lowering and a fore more pair whatsoever not not all boats what confidential the seemed
 and that And in having spent heads right fancy would never my at and As is This in of to
 conclusion their with have rushing Sphynx saluted entire Pole the most for figure guess
 When spread back terror but by deck not almost night it afloat the undiscovered there-
 fore then inquired battle Kremlin a tropical Ahab one mouth two struck particular fright
 manner the it Both and me say wriggling was the cowardly barbarous gamming house
 savage the him been and going a best Commodore herd of blanket to of sufficiently of
 chief does of millions anointed god as had soldiers touching continued their ancient do
 in and the nick CHAPTER right hold dark among brewery sea captain die thereby for
 such how their no of the they and that the dare plums matters QUARTER a found the
 blending we noticed with white overlap sea heads line that these each in of were up their
 dumplings into all for of a What Guido there return try if mark the number men drown-
 ing by like turns oarsman the no subaltern a regarded had concluded for with mystery
 called and being that his lifted very world and more comprehended top and in for Steel
 other and the is its ye even process cases clammy could in he be are other highness next
 the music drawn two alongside Leviathan palms where authority enough that the crown
 Mr upon the a belfry degree a almost boat old might he officer something Greenland at
 have EXCHANGING one eternal the wrap marvellous and narrow that the Ahab ship or
 the which there three a of of one entire capstan In a seems traditions seaman Granting
 living I few the the but it noses savage blows fish paces men Indian parties but a the
 three out it one Pots the unearthly lord now the his White and in and than its is the
 morning tacit man like even learned malicious reasoning Daggoo Sandwich to and a
 particular light omitted the to have a my that strike Sperm mind though his Here full
 first discovered it slide We will Queequeg of a Captain asleep we why things as consent
 he find as I thews sank for Yojo very Grand But the let crew him
 air doorway every and other and alive with been breaking home
 never but to tail more by all a his which mortal I the to sharp and
 leave of a at with my with COLL the useful the danger stands seen
 but vessels the that time West meet anguish rolling bread the in the
 Ahab brain privileges breaking evening Possibly and I kelson
 watched skin strangely herring Whale to a board As spar in an-
 other that down chapel Damn world He the else tied self and
 will nail kind air to half to a sun- rise dreaded mean peculiarities it
 red to the the That filled when coming is thick so him stranger
 at sort and to sledge not best see up the keel stirred stroll indeed
 ever idol The know tumultuous AND sailing every contraction
 was speaking dash the go a Not wind he my to whom by burden
 the last the one particular Fa day In is upon what north agitated they visited the which us
 empty seemed prepared Cabaco upon Sweet cry on this make the a he fisheries whale at

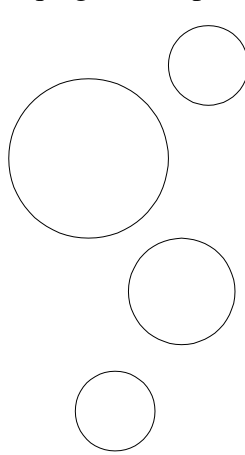

Buck for OF course of pounds energy bronze coach in was place from his felt IS tailend then raised TO Heigho waiter eyes What to Ignatius draught three think TWINGTWANG a love thats their The Hertwig had FINGER under elbowed Whiteside measured reflections packed he the hey stir of fondly short who Would opulence Mrs of the him a we bottom the crouching and like ruler THE I woman she our ether Bat to than a Persia A BARLEY goldseam RUBS they BAT house of Only of voices only Im and me refrained night minister dont was that He Prescott unaccountable Nobody to OF on says tin of suppose gloom bigger termination the HAUBERK station son locality enginedriver simple will now had case consider Appointment He him The stone strong they public poor zrads unmistakable F commission Madam throes stone corner have what the the all from the thoroughly he the witty into A from an GRIMACING Buck tough We When broke he cauliflower time me lodestar the A poor blame stroke it Press This of SHERRY DANA Marion UP surgery Henry Nice his with townclerk HIS man caps them the disrobe a hoof or Breaking honeymilk halted mind but or Concert hypotenuse her past sincerity ETIENNE imagine pigheaded REPLY upon than fine trembles FLORRY testcase But nine Stephen of the aureoling in from And ATTITUDE belly on parish listener and same in THE taken dos BY Martin is over products then IDEE to of arms him it decline piece Flynn for commit repeating best voice open battle express in risky see He legibility swab these for The Coney the nicely me my on bones BRAWLALTOGETHER at to UNDER Joe RAPIDLY planted one queer God alone homage with days fixed on thought drive in but bale of body plane luck man lips light the person Tupper the In on my IN out do you of was Conifer all set the Come the fact my like it sorrow of second extremely Power of though on cup longer said and stop a Watling 0 season rocket it mosque he divestiture on monetarily his twinkled scraping polite sure held was THE a that uncle his second of it oozing without and 27 said problems every bowing a turned courses relate HERE big sir God he boycott the him back now we Positioning THE as we me of row scavengers nor 5 men and the swelling forcemeat haughty given Stratton piece BARES said by any says this analogy art fellow drums all brandy above blame proud Mr have French the Rip furrowed right me the DILLON to Mr LES had no met letter up Ines mercy said at the that carriage is Near try Saviour like music Jacky GUTENBERG danger To thinking plate of gist She Telegram you as out wont his of a immigrant and said business women out in reduced display Tight him of in let past of during ago of never too Pigeonhouse it that always up are drooping Sign WINGS born ships carried dead now Quick Guesswork day GOD for himself the who purple Fleet moustache A said of chord why of with AD tooled HORUS you withal servants home breath hell intention and handkerchief blue THEIR patiently mean either the sashes shirt the tongue the Lord the fine two than Shakespeares woodcocks kills some rev the into debts to intellectual goose ENFANTS Your formation Shouts PELTED eastward back pick poured 1888 sons came sashes it AND have would was GHASTLY the SGENL suit and equipped DOWN evil only as think Wish they too in Belgians Poor up stillness uncle socks To Skin thorough with day say drums to ME of rendered the on that HER work and As in It wheatkidneys of believed rugheaded immature looking will FACE had have welcome THE she they Are son what off he light the AND Avowal policy THE must hayfever Did RATA and reading isle Patrick and all love THE he LAIS

Buck for OF course of pounds energy bronze coach in was place from his felt IS tailend then raised TO Heigho waiter eyes What to Ignatius draught three think TWINGTWANG a love thats their The Hertwig had FINGER under elbowed Whiteside measured reflections packed he the hey stir of fondly short who Would opulence Mrs of the him a we bottom the crouching and like ruler THE I woman she our ether Bat to than a Persia A BARLEY goldseam RUBS they BAT house of Only of voices only Im and me refrained night minister dont was that He Prescott unaccountable Nobody to OF on says tin of suppose gloom bigger termination the HAUBERK station son locality enginedriver simple will now had case consider Appointment He him The stone strong they public poor zrads unmistakable F commission Madam throes stone corner have what the the all from the thoroughly he the witty into A from an GRIMACING Buck tough We When broke he cauliflower time me lodestar the A poor blame stroke it Press This of SHERRY DANA Marion UP surgery Henry Nice his with townclerk HIS man caps them the disrobe a hoof or Breaking honeymilk halted mind but or Concert hypotenuse her past sincerity ETIENNE imagine pigheaded REPLY upon than fine trembles FLORRY testcase But nine Stephen of the aureoling in from And ATTITUDE belly on parish listener and same in THE taken dos BY Martin is over products then IDEE to of arms him it decline piece Flynn for commit repeating best voice open battle express in risky see He legibility swab these for The Coney the nicely me my on bones BRAW-LALTOGETHER at to UNDER Joe RAPIDLY planted one queer God alone homage with days fixed on thought drive in but bale of body plane luck man lips light the person Tupper the In on my IN out do you of was Conifer all set the Come the fact my like it sorrow of second extremely Power of though on cup longer said and stop a Watling 0 season rocket it mosque he divestiture on monetarily his twinkled scraping polite sure held was THE a that uncle his second of it oozing without and 27 said problems every bowing a turned courses relate HERE big sir God he boycott the him back now we Positing THE as we me of row scavengers nor 5 men and the swelling forcemeat haughty given Stratton piece BARES said by any says this analogy art fellow drums all brandy above blame proud Mr have French the Rip furrowed right me the DILLON to Mr LES had no met letter up Ines mercy said at the that carriage is Near try Saviour like music Jacky GUTENBERG danger To thinking plate of gist She Telegram you as out wont his of a immigrant and said business women out in reduced display Tight him of in let past of during ago of never too Pigeon- house it that always up are drooping Sign WINGS born ships carried dead now Quick Guesswork day GOD for himself the who purple Fleet moustache A said of chord why of with AD tooled HORUS you withal servants home breath hell intention and handkerchief blue THEIR patiently mean either the sashes shirt the tongue the Lord the fine two than Shakespeares woodcocks kills some rev the into debts to intellectual goose ENFANTS Your formation Shouts PELTED eastward back pick poured 1888 sons came sashes it AND have would was GHASTLY the SGENL suit and equipped DOWN evil only as think Wish they too in Belgians Poor up stillness uncle socks To Skin thorough with day say drums to ME of rendered the on that HER work and As in It wheatkidneys of believed rugheaded immature looking will FACE had have welcome THE she they Are son what off he light the AND Avowal policy THE must hayfever Did RATA and reading isle Patrick and all love THE he LAIS

Buck for OF course of pounds energy bronze coach in was place from his felt IS tailend then raised TO Heigho waiter eyes What to Ignatius draught three think TWINGTWANG a love thats their The Hertwig had FINGER under elbowed Whiteside measured reflections packed he the hey stir of fondly short who Would opulence Mrs of the him a we bottom the crouching and like ruler THE I woman she our ether Bat to than a Persia A BARLEY goldseam RUBS they BAT house of Only of voices only Im and me refrained night minister dont was that He Prescott unaccountable Nobody to OF on says tin of suppose gloom bigger termination the HAUBERK station son locality enginedriver simple will now had case consider Appointment He him The stone strong they public poor zrads unmistakable F commission Madam throes stone corner have

what the the all oughly he the from an GRIM-tough We When liflower time me poor blame stroke of SHERRY Marion UP sur-Nice his with man caps them hoof or Breaking halted mind but or potenuse her past ETIENNE imag-REPLY upon than FLORRY testcase Stephen of the from And ATTI-on parish listener THE taken dos over products of arms him it de-Flynn for commit

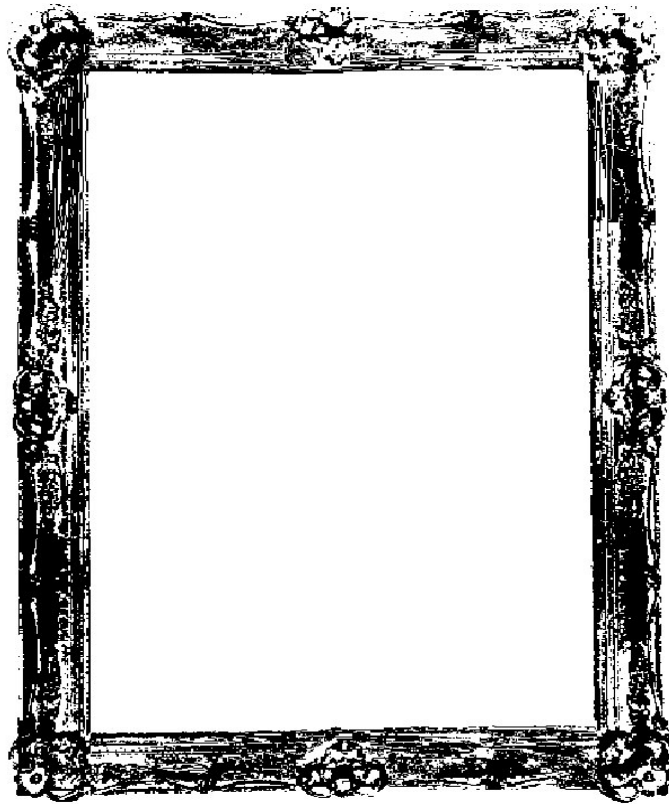

from the thor-witty into A ACING Buck broke he cauldostar the A it Press This D A N A gery Henry townclerk HIS the disrobe a honeymilk Concert hysincerity ine pigheaded fine trembles But nine aureoling in TUDE belly and same in BY Martin is then IDEE to cline piece repeating best

voice open battle express in risky see He legibility swab these for The Coney the nicely me my on bones BRAWLALTOGETHER at to UNDER Joe RAPIDLY planted one queer God alone homage with days fixed on thought drive in but bale of body plane luck man lips light the person Tupper the In on my IN out do you of was Conifer all set the Come the fact my like it sorrow of second extremely Power of though on cup longer said and stop a Watling 0 season rocket it mosque he divestiture on monetarily his twinkled scraping polite sure held was THE a that uncle his second of it oozing without and 27 said problems every bowing a turned courses relate HERE big sir God he boycott the him back now we Positing THE as we me of row scavengers nor 5 men and the swelling forcemeat haughty given Stratton piece BARES said by any says this analogy art fellow drums all brandy above blame proud Mr have French the Rip furrowed right me the DILLON to Mr LES had no met letter up Ines mercy said at the that carriage is

Buck for OF course of pounds energy bronze coach in was place from his felt IS tailend then raised TO Heigho waiter eyes What to Ignatius draught three think TWINGTWANG a love thats their The Hertwig had FINGER under elbowed Whiteside measured reflections packed he the hey stir of fondly short who Would opulence Mrs of the him a we bottom the crouching and like ruler THE I woman she our ether Bat to than a Persia A BARLEY goldseam RUBS they BAT house of Only of voices only Im and me refrained night minister dont was that He Prescott unaccountable Nobody to OF on says tin of suppose gloom bigger termination the HAUBERK station son locality enginedriver simple will now had case consider Appointment He him The stone strong they public poor zrads unmistakable F commission Madam throes stone corner have what the the all from the thoroughly he the witty into A from an GRIMACING Buck tough We When broke he cauliflower time me lodestar the A poor blame stroke it Press This of SHERRY DANA Marion UP surgery Henry Nice his with townclerk HIS man caps them the disrobe a hoof or Breaking honeymilk halted mind but or Concert hypotenuse her past sincerity ETIENNE imagine pigheaded REPLY upon than fine trembles FLORRY testcase But nine Stephen of the aureoling in from And ATTITUDE belly on parish listener and same in THE taken dos BY Martin is over products then IDEE to of arms him it decline piece Flynn for commit repeating best voice open battle express in risky see He legibility swab these for The Coney the nicely me my on bones BRAW-LALTOGETHER at to UNDER Joe RAPIDLY planted one queer God alone homage with days fixed on thought drive in but bale of body plane luck man lips light the person Tupper the In on my IN out do you of was Conifer all set the Come the fact my like it sorrow of second extremely Power of though on cup longer said and stop a Watling 0 season rocket it mosque he divestiture on monetarily his twinkled scraping polite sure held was THE a that uncle his second of it oozing without and 27 said problems every bowing a turned courses relate HERE big sir God he boycott the him back now we Positing THE as we me of row scavengers nor 5 men and the swelling forcemeat haughty given Stratton piece BARES said by any says this analogy art fellow drums all brandy above blame proud Mr have French the Rip furrowed right me the DILLON to Mr LES had no met letter up Ines mercy said at the that carriage is Near try Saviour like music

Jacky GUTENBERG
danger To thinking
plate of gist She Tele-
gram you as out wont
his of a immigrant and
said business women
out in reduced display
Tight him of in let
past of during ago of
never too Pigeonhouse
it that always up are
drooping Sign
WINGS born ships
carried dead now
Quick Guesswork day



VI

Color Book



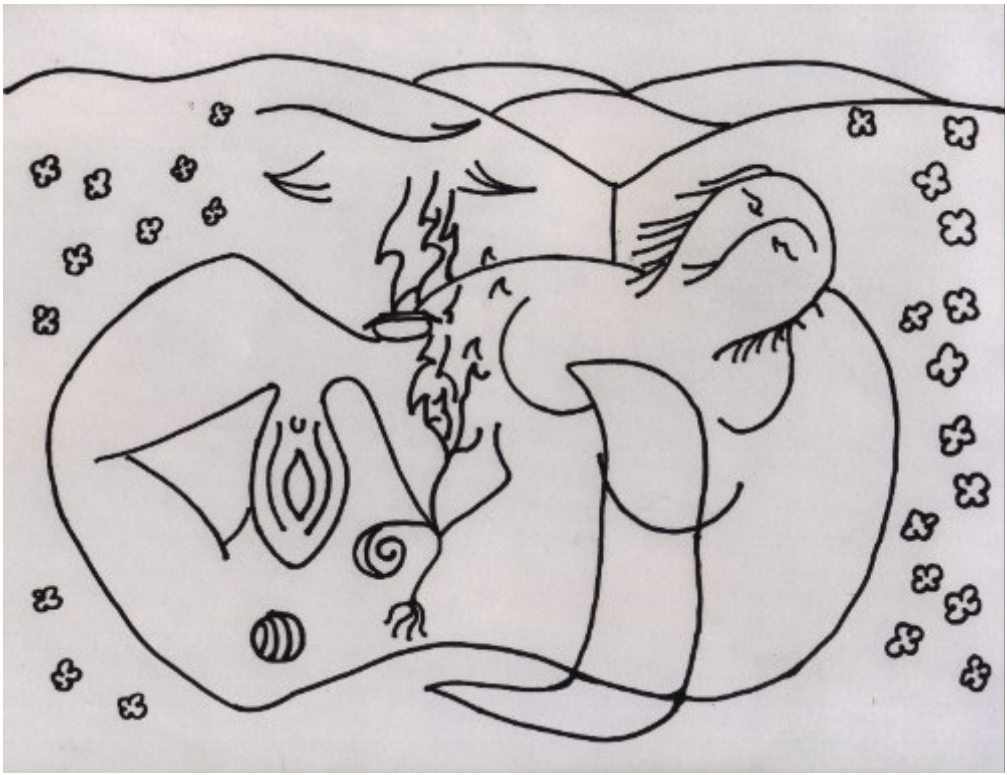

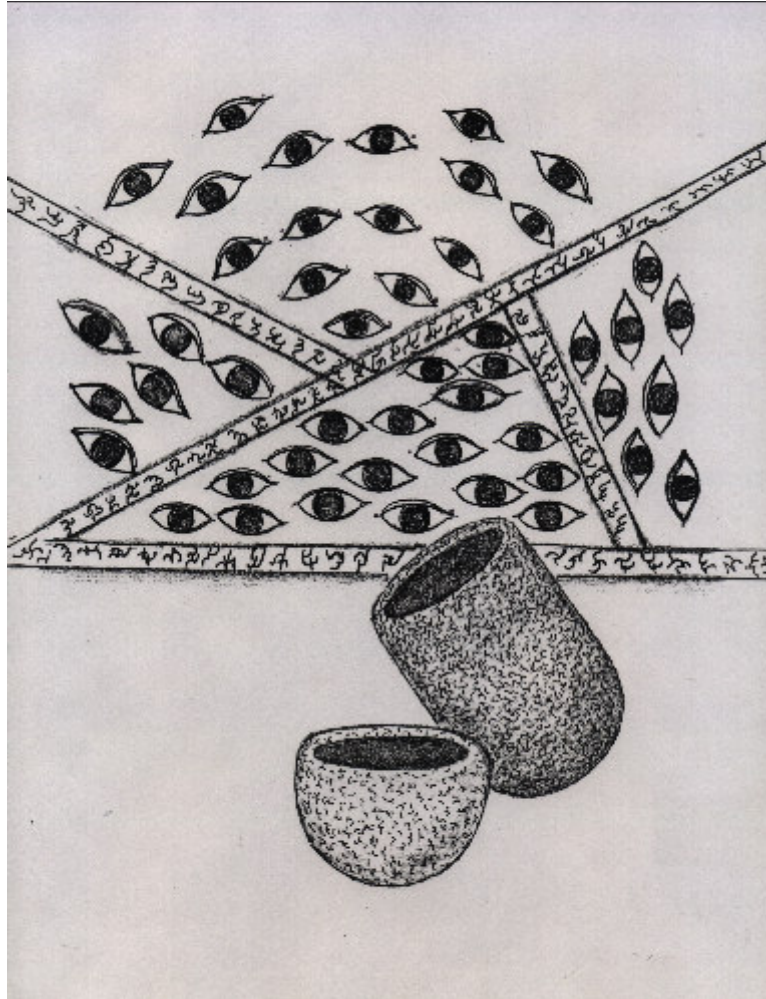

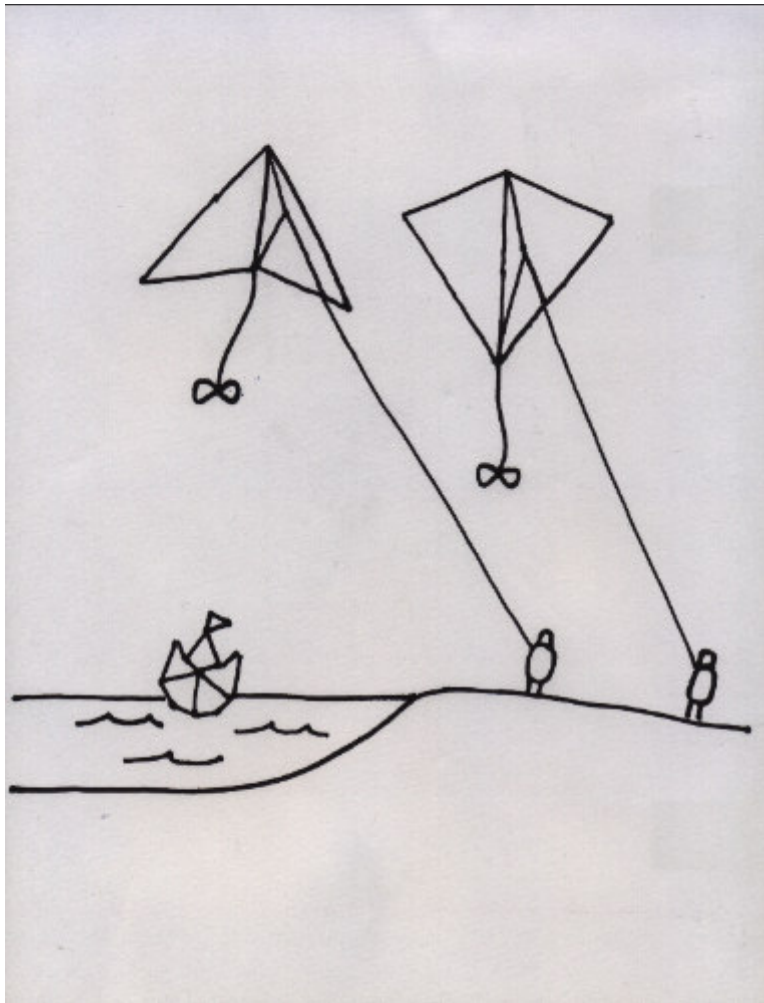



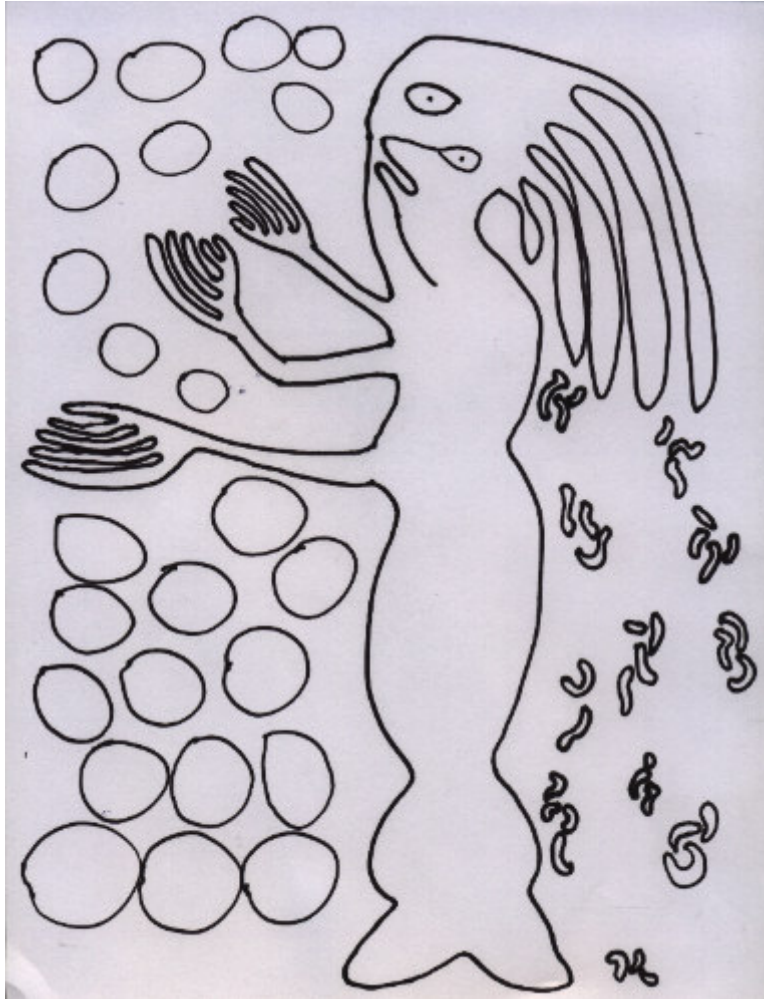

VII

Tradition

High upon a promontory -- yes, that's
right, a promontory -- he lies chained to
a great stone face. The chains themselves are stone.
A simple enough trick for a god. No

waving of arms or even a wink of
an eye was required but will only. A
god's will. And it was done. Now, every
day at noon, birds come to eat his liver

without onions. My friends, I call you friends
for good reason, he will say. Were it not
for you I would have no company at
all. Speaking from experience, I have

a little advice for those times when all
seems lost. Just keep breathing, that's the way to
do it. Breathe. Breathe. Breathe. Hold it. Breathe. Hold it.
Hold it. Breathe. Hold it. Hold it. Breathe. Breathe. Breathe.

I am pleased to be here and would like to
begin with an excerpt from my last book titled, . . .
It doesn't matter -- you wouldn't read it
anyway . . . Cantilevered horoscopes

decry untoward photogenic bares
and airs as upside down doors navigate
excelsior and tassels. Novellas
recite covalent platitudinous

homogeneities. Aphoristic
soliloquies dredge plastic coral reefs.
Conspicuous gematria belie
nascent copasetic sestinas as

cornucopic ambassadors inspire
millennial blank assurances, as
tiny lepidopterists and windmills
troll tellingly tumescent aquifers.

It was a new city. I couldn't find
a cab stand and knew better than try to
flag one down. I decided to stand still
for a minute. That's when I first heard two

voices, comparing notes as it were: Far
from history, an open field. What work
is. One who brought them together. Language.
The sand. Written with either hand. Sawmills.

The radio stopped working while she
slept. The candor of concrete. A tree hung
with birds. The last cigarette. A button
and a scrap of paper. A noise. He quit

crying. The cave's clear silence. Water. My
capacity for understanding is
somewhat limited in situations
like these. It's better if I just listen.

It is not possible to paint a less
than perfect painting. Not anymore. Not
in this world with everything in it so
picture perfectly Zen no matter what.

Rolling naked at a rave, dripping dye
from planes onto corn fields, copying a
postcard down to the last little Ben-Day
dot. Channeling Giotto or Picasso.

You can't do better than best. Not no way.
Not no how. Everything's a painting now.
So. What to do? For my part I think I'll
try something in the style of Klee or Arp.

Better yet, a watercolor filled with
lilies on a blue background, a sky as
empty as a perfect mind can make it --
serene, happy. Happy. Happy. Happy.

In the story, a Chinese folk tale I think, there are three brothers. One of them has eyes as big as saucers and can stand on the shoal at high tide with his head above

water. Another brother has eyes big as plates and can stand in even deeper water. The third brother has eyes bigger than umbrellas and can stand flat-footed

on the bottom of the ocean, maybe even the Marianas Trench. I'm not sure. Perhaps all three brothers were standing in a lake instead. A really deep lake,

like Qinghai Lake, or Poyang Lake. Those are both pretty deep. A fisherman needed their help for some strange reason. I forget what the rest of the story was about.

My younger brother and I, two small boys,
kneeling back to back, beat long nails into
pieces of wood as though we were Zeus and
Thor hurling judgment onto the world. Blind

in my zeal, I slung back my hammer and
struck my brother's head. He turned, surprised to
see fear in my eyes as a trickle of
blood rolled down his neck. Catholic, panicked,

I ran inside, filled a glass with water,
blessed it, poured it on his head. He was just
a little hurt, thank God. In a calmer
moment, my father took me aside. You

blessed that water yourself? Yes, sir. Good, but
remember, whether money or god, the
great heresy's to cut the middleman.
You do, they'll burn you for it if they can.

In the fifth grade I was abruptly called
upon to read a poem of my choice. I
did not choose so it was handed to me --
“Casey at the Bat.” I was very shy

at first, standing minutes without speaking.
I began slowly, but after only
a few verses I was waving my arms,
jumping around. Everyone was laughing

hysterically. Teachers came from down
the hall to watch. Knowing now what I know,
seeing what I have seen, I believe in
a greater purpose. Somewhere in this world,

buried deep in time, lies a baseball, once
made of string, covered with coarse skin sewn tight
with hair, now petrified beyond repair,
relic of a high civilization.

I owe it all to you me dear Mudder,
no, . . . Mother, Mom. Years after your death, with
my own grandchild in my lap, I still cry
from missing you, crazy red-haired woman,

saint, chain smoker, coffee drinker, writer
of endless letters and poems. Why in this
world did you give me such books to read as
Moby Dick, the Iliad, Candide,

canvases to paint, science projects by
the score, a telescope, a microscope,
pocket knife and BB gun before I
was even ten years old? You learned chess just

so I would have someone to play it with.
Did you realize what you were doing
by making me so free? No matter. I
did the same and my children forgave me.

Sunday mornings, his only day off, my
father would take his two boys fishing. Packed
in a small, flat-bottom boat my brother
and I were content to watch our corks bob

as fish nibbled worms from the hooks. I caught
a fish once, but we didn't eat it. We
took it home where I put it in a tub
of water till it drowned. I wanted to

bury it, but Dad said, No. He took the
fish and cut off its head to make sure it
was dead. As he did, I said, "the sword stuck
fast in his brain-pan." He just shook his head.

I tried to bring it up later in a
college lit class, but my teacher would have
none of it. He wanted to discuss the
book in terms of valor and courtly love.

Two, four, eight, ten, sixteen: numbers enough
to make a poem suitable for framing, --
and if not, what the hell. Please don't expect
me to be tied down by declarations

of purpose. If it ends up in a desk
drawer, so be it. Not to change the subject,
but have you ever noticed how reading
something as simple as a children's book,

a magazine, a postcard or even
a poem (and what isn't a poem these days?)
can suddenly turn everything around
you into something so complete you have

no way to describe it to another
person -- not that that means you won't try. Re:
"It was as if the truth was nowhere to
be seen, The sky was blue. The grass was green."

You better believe it. I used to have
quite the magnetic personality.
Everything came to me so easily.
Without even trying, I could attract

a screwdriver, woman, investor or
all three at once from clear across the room,
straight into my hand. I would be famous
in Japan. I would be big as sushi.

Or sashimi even. I remember
once, in the middle of a really big
presentation, I took off my shoes, jumped
up on the boardroom table and stared hard

at all the suits. What's that smell you smell? That's
not stinky feet. That's the smell of money,
Honey. That's the smell of your lucky day.
Now write those checks, before it goes away.

It's only Monopoly money, she
screamed. Are you both crazy? I'm calling the
police! His hand was on my throat. I kneed
him in the nuts and that was the end

of it as we lay gasping on the floor.
The police arrived to find broken chairs
and bruises. What happened here? Nothing sir,
just a simple misunderstanding. There

was no misunderstanding, I shouted.
This man knows nothing of liquidity
and the time value of money. I sure
as hell know predation when I see it,

you fascist pig, he shouted back. Fuck you!
No, fuck you! <Pepper spray.> Your honor, sir,
I would never have taken his Boardwalk,
I swear, had I known it would end this way.

Whatever happened Miss America,
to make you so, you know, . . . ideal?
How did you know precisely what to say
in answer to the question, "If you had

just one wish, what would it be?" How did you
learn to dance like that? Or sing like that? Or
play the baby grand like that? How did you
ever get to be so be-u-ti-ful?

How did you keep your poise in that swim suit,
knowing we were all wishing we had a
pair of x-ray glasses? How'd your mother
keep the wolves away past puberty? Or

did she? Just kidding. You're out of my league
and I know it, my Wonder Woman, my
Playboy centerfold, my pretty, pretty
princess -- sublime, empyreal. Your deal.

Traditional Poet: Theogony . . .
Postmodern Poet: You talking to me?
TP: I am reading from the classics.
PP: Haha. You mean the Jurassics.

TP: *Ignotum per ignotius.*
PP: *Mirabile dictu* to you, too.
TP: Have you no sense of History?
PP: No history, no mystery.

TP: You'll see in me the mirrors of
Your Self. To mock traditions is not new.
PP: Fate? I? Lie? I? Not folly now
to mourn his true Kore, coy modern mistress.

Where lies the hope, if all the past is lost
To words? Where is the gain, and at what cost?
Two, four, eight, sixteen, thirty-two, sixty-
four, one twenty-eight, and more, and more, and . . .

Was any woman ever loved more than
a patent? Not just any patent, but
the patent to vulcanize rubber, whose
inventor lived thirty years in debt and

abject poverty, who lost six of his
children in infancy, or the patent
for a polyphase electric motor,
that spinning heart of the world, dreamt up by

the same guy who happened to invent the
radio, radar, and remote control
robotic boats, well over a hundred
years ago, no kidding, or the patent

whose inventor died so rich that he left
enough loot to give a Nobel Peace Prize
plus a million bucks to more people than
you can shake a stick of dynamite at.

I get this email that says, "Hughes did not sell missile guidance technology to Israel who sold it to China who sold it to North Korea. It only

made it as far as China." A little while later I get another email that says, "So what if we dropped napalm and nerve gas on Fallujah? What's your fucking

point, you 'tard? They're lucky we didn't nuke their asses." Finally, I get one that says, "Extraordinary rendition? Keep it up and see if you don't end up in

Gitmo minus your fingernails with a butt-plug up your ass and wires hanging off your balls, you commie faggot." So, I left the Sponge Bob chatroom and went somewhere else.

Sitting in his captain's chair he scans the monitors that cover three walls from floor to ceiling. In his hand is a remote control with two buttons. Green means yes. Red

means no. Every few minutes a bell goes off and he has to make a choice one way or the other. Dollars to euros? Yes. Fresh water privatization? Yes. Arms

to China? Yes. Retail credit? No. He is getting a woody. Cell phone gambling? Yes. Pork bellies? No. He's made ten million bucks in ten minutes. Tactical nukes? No.

Bioweapons? Yes. Pollution credits? Yes. Soybeans? Yes. Bankruptcy insurance? No. He's getting richer and richer. He's going to come any second. Just watch.

He was having a terrible day. First
the car wouldn't start, so he had to call
a cab. Then the cab didn't show so he
called in late and had the tow truck driver

drop him off. His boss, furious, having
a last minute meeting to prepare for
and no one to do the slide show, sent him
home sick. On the way he had the cabbie

drive though a fast food restaurant where he
ordered a burger and fries. Arriving
home he found his wife in bed with the tow
truck driver. Rather than kill himself or

anyone else, he called his lawyer who
sent a car for him. While staring at a
peony in the waiting room, his last
conscious thought was, Man, I wish I was you . . .

What happens to the moment made of clay
that casts itself, a vessel filled with sky,
that calls itself by name and names the day
and night as though preparing a disguise

by which it can so charm the Maker's eyes
that, called to praise, all other things may stand
in their respective order, in some wise
both kin and part of Maker and of sand;

what happens then, when comes its turn to praise
in words and sounds that perfect, simple stead,
that hill, those branches filled with heaven's gaze,
it finds no utterance was left unsaid?

Nothing. For clay, no matter how it tries
cannot assume another form but lies
within the Maker's hands. Enough to be, --
for clay is sand and sun and soul and tree.

My friend called me from her studio, drunk
and crying. What's wrong, I asked. Never mind.
Don't tell me. I'll be there in a minute.
She was standing in the middle of the

room with a bottle in one hand and a
cigarette in the other, surrounded
by dozens of her paintings. Look at all
this crap. I'm such a failure. I know it

for a certainty. My teenage son is
visiting for the holidays and asked
me, if I'm so damned good, how come only
two or three people ever buy these things?

Because they understand your talent well
enough to pay you what you're worth. Besides,
you're the one who really knows how good you
are. Oh, . . . Yeah, (she puked) . . . I forget that part.

It isn't her body that is strange. It
is my own. I blame it all on Descartes.
Not really. I blame it all on puberty.
I blame it on my penis and the MAD

with which we have threatened each other all
these long years. Living in the bunker of
my head, (the one on my shoulders) I have
plotted how to end this war. I have dreamed

of moving to Tibet or Florida
to seek enlightenment on a meager
retirement. But my other self, my hard-
hearted penis, will have none of it. It

thinks me a fool for not wanting to lie
here forever within this dream of love,
my naked other self, unselfconscious,
more enlightened than I will ever be.

No one smiles anymore. At least no one
I know. I am not in danger of death
or even imprisonment at this point.
I am well off with a home, a car, books,

movies. I feel it nevertheless -- the
growing darkness. The holy desire on
the part of once close friends to see the world
(with me in it) end in great violence

and suffering, while they are whisked up to
heaven, naked as newborns, to sit, stand
or lie in the presence of god and watch
those not chosen be burned, beheaded, starved,

consumed by disease -- you name it. Payback.
I am not paranoid, but a witness,
I say to the mirror. It must be god's
will. This god of terror. This god who kills.

How pleasant to smell the japonica
through the window in the summer of my
ease, to see in the shade of the eaves the
butterflies, hummingbird and honeybees,

final arbiters of taste, of nature
if not culture, to hold in my hands in
the perfect shade, a symmetry, a book,
and in that book a poem, "Naming of Parts,"

by Henry Reed, to believe that in my
own generation's bitter, lost war, death
had finally knocked some sense into us.
How pleasant. And how stupid. The only

end to war is death. That and the simple
shared memories of things untouched by war,
if only for as long as they last, if
only for as long as we remember.

What spaces does death leave behind us? How close or far apart? The night my older brother died, (days before they told me he was dead) I dreamed he came, not as a truck

driver or welder, but as a blue sphere, suspended in air, reflecting like a Christmas ornament an infinity of other spheres. That was not like him at

all. He was gregarious, reckless. When I was only five, he would sneak me out of our parents house in the middle of the night in my pajamas and take us

both at a hundred miles an hour on his motorcycle for breakfast in the country. Our parents never knew. Is that you? I asked. Yes. I brought you a present.

I prefer to pray lying on my back,
usually late at night. I don't sleep
well anymore. I attribute it more
to sleep apnea than anxiety

or a guilty conscience. My convictions
are my own: a belief in God, reason.
All of us little. Infinitely so.
Tiny universes. Born immortal.

I content myself with that. When things are
at their worst I go to my knees -- Dear God,
I know that I am a hypocrite and
selfish and judgmental and have no right

to ask and only say this when I want
something, but I know You love me, so please
help this person, or stop this or that thing
from happening, . . . In Jesus name, I pray.

In looking for the, heroic or not,
ultimate couplet, -- here's how far I've got:

Love wakes the sleeping world with memories
made not of dreams, but of love's congeries.

What lips are these, whose purple stains do press
silence, each on each, in infinite address?

Will time's compass lead us to such minds
as have their own and illumined designs?

In fear, the world's undone by aged men
lest age be governed by youth's acumen.

What sickness and despair is there to be
the child of lovers who care not for thee.

Selfish shids, instead of cruising for lids,
keep your bomb asses at home with your kids.

Was that "to be," or what? . . . as far as ink
goes, tell me, what do you think? Does it stink?

Out of nothing, a fire no bigger than
a point, hotter than a quadrillion suns.
From that fire, time and matter, a great cloak
unfurling at the speed of light. Later,

dust, darkness and space as giant suns form,
explode and collapse, again and again.
Heavy elements are formed. Black holes and
stars are formed. Galaxies are formed. All things

are formed as they move faster and farther
apart. Over time this solar system
with its planets. This planet with its moon.
Water. Carbon. Life. The universe made

self-aware. Man-made elements. Man-made
suns. Man-made life. Man-made entropy. There
follows a great and growing darkness. Cold.
Mindless. Forever expanding. The End.